

# **SERVICE MANUAL**

**Models**

**EH63, 64, 65 and EH72  
ENGINES**

PUB-ES2158  
Rev. 08/09

**Robin America, Inc.**

905 Telser Road • Lake Zurich, IL 60047 • Phone: 847-540-7300 • Fax: 847-438-5012  
*e-mail: [sales@robinamerica.com](mailto:sales@robinamerica.com) • [www.subarupower.com](http://www.subarupower.com)*

© Copyright 2009 Robin America, Inc.

# CONTENTS

<i>Section</i>	<i>Title</i>	<i>Page</i>
<b>1.</b>	<b>SPECIFICATIONS</b> .....	<b>1</b>
<b>2.</b>	<b>PERFORMANCE</b> .....	<b>2</b>
<b>3.</b>	<b>FEATURES</b> .....	<b>7</b>
<b>4.</b>	<b>GENERAL DESCRIPTION OF ENGINE COMPONENTS</b> .....	<b>8</b>
<b>5.</b>	<b>DISASSEMBLY AND REASSEMBLY</b>	
5-1	PREPARATIONS AND SUGGESTIONS .....	15
5-2	SPECIAL TOOLS .....	15
5-3	DISASSEMBLY PROCEDURES .....	16
5-4	REASSEMBLY PROCEDURES .....	32
5-5	BREAK-IN OPERATION .....	48
<b>6.</b>	<b>LUBRICATION SYSTEM</b> .....	<b>49</b>
<b>7.</b>	<b>FUEL SYSTEM</b> .....	<b>52</b>
<b>8.</b>	<b>ELECTRIC SYSTEM</b> .....	<b>57</b>
<b>9.</b>	<b>TROUBLESHOOTING</b> .....	<b>63</b>
<b>10.</b>	<b>INSTALLATION</b> .....	<b>69</b>
<b>11.</b>	<b>SERVICE DATA</b>	
11-1	STANDARD DIMENSIONS AND SERVICE LIMITS .....	70
11-2	TIGHTENING TORQUE .....	76
<b>12.</b>	<b>MAINTENANCE AND STORAGE</b> .....	<b>77</b>

# 1. SPECIFICATIONS

MODEL		EH63D	EH64D	EH65D	EH72D
Type		Air-Cooled, 4-Stroke, V-Twin Cylinder, Horizontal P.T.O. shaft, OHV Gasoline Engine			
Bore x stroke	mm (in.)	2 - 80 x 65 (3.15 x 2.56)			2 - 84 x 65 (3.31 x 2.56)
Displacement	cm <sup>3</sup> (cu. in.)	653 (39.9)			720 (43.9)
Compression Ratio		8.3			
Continuous Output	kW (HP) / r.p.m.	10.8 (14.5) / 3600	11.9 (16.0) / 3600	12.7 (17.0) / 3600	13.4 (18.0) / 3600
Maximum Output	kW (HP) / r.p.m.	13.4 (18.0) / 3600	15.3 (20.5) / 3600	16.4 (22.0) / 3600	18.6 (25.0) / 3600
Maximum Torque	N•m / r.p.m. (kgf•m / r.p.m.) (ft•lb. / r.p.m.)	43.3 / 2000 (4.41 / 2000) (31.90 / 2000)	44.3 / 2200 (4.52 / 2200) (32.69 / 2200)	45.6 / 2500 (4.65 / 2500) (33.63 / 2500)	53.6 / 2500 (5.5 / 2500) (39.78 / 2500)
Direction of Rotation		Counterclockwise as viewed from P.T.O. shaft side			
Cooling System		Forced Air Cooling			
Valve Arrangements		Overhead Valve (OHV)			
Lubrication		Full pressure type (Trochoid Pump)			Full pressure type with oil Cooler
Lubricant		Automotive Engine Oil SAE #20, #30 or 10W-30; Class SE or higher			
Capacity of Lubricant	L (U.S. gal.)	1.55 (0.41)			
Carburetor		Down Draft, Float Type			Down Draft, Float Type (With Accel Pump)
Fuel		Automotive Unleaded Gasoline			
Fuel Feed System		Diaphragm Pump (Pulse type)			
Ignition System		Flywheel Magneto (Solid State)			
Spark Plug		NGK-BP6ES			
Charging Capacity	V - A	12 - 15 (STD) 12 - 30 (Option)			
Starting System		Electric Starter			
Governor System		Centrifugal Flyweight Type			
Air Cleaner		Double Element Type			
Dry Weight	kg (lb.)	44 (97.0)			46 (101.3)
Overall Length×Width×Height	mm (in.)	317 x 477 x 475 (12.5 x 18.8 x 18.7)			

\* Specifications are subject to change without notice.

## **2. PERFORMANCE**

### **2-1 MAXIMUM OUTPUT**

The maximum output is the output of an engine with its throttle valve fully opened under the condition that all the moving parts are properly worn in after the initial break-in period.

A new engine may not produce full maximum output while its moving parts are still not broken-in.

NOTE :

Power curves shown in the following charts are made in conformity to SAE internal combustion engine standard test code J1349

### **2-2 CONTINUOUS RATED OUTPUT**

The continuous rated output is the output of an engine at optimum governed speed which is most favorable from the view point of engine's life and fuel consumption.

When the engine is installed on a certain equipment, it is recommended that the continuous output required from the engine be kept below this continuous rated output.

### **2-3 MAXIMUM TORQUE**

The maximum torque is the torque at the output shaft when the engine is producing maximum output at certain revolution.

2-4 PERFORMANCE CURVES

**EH63D**

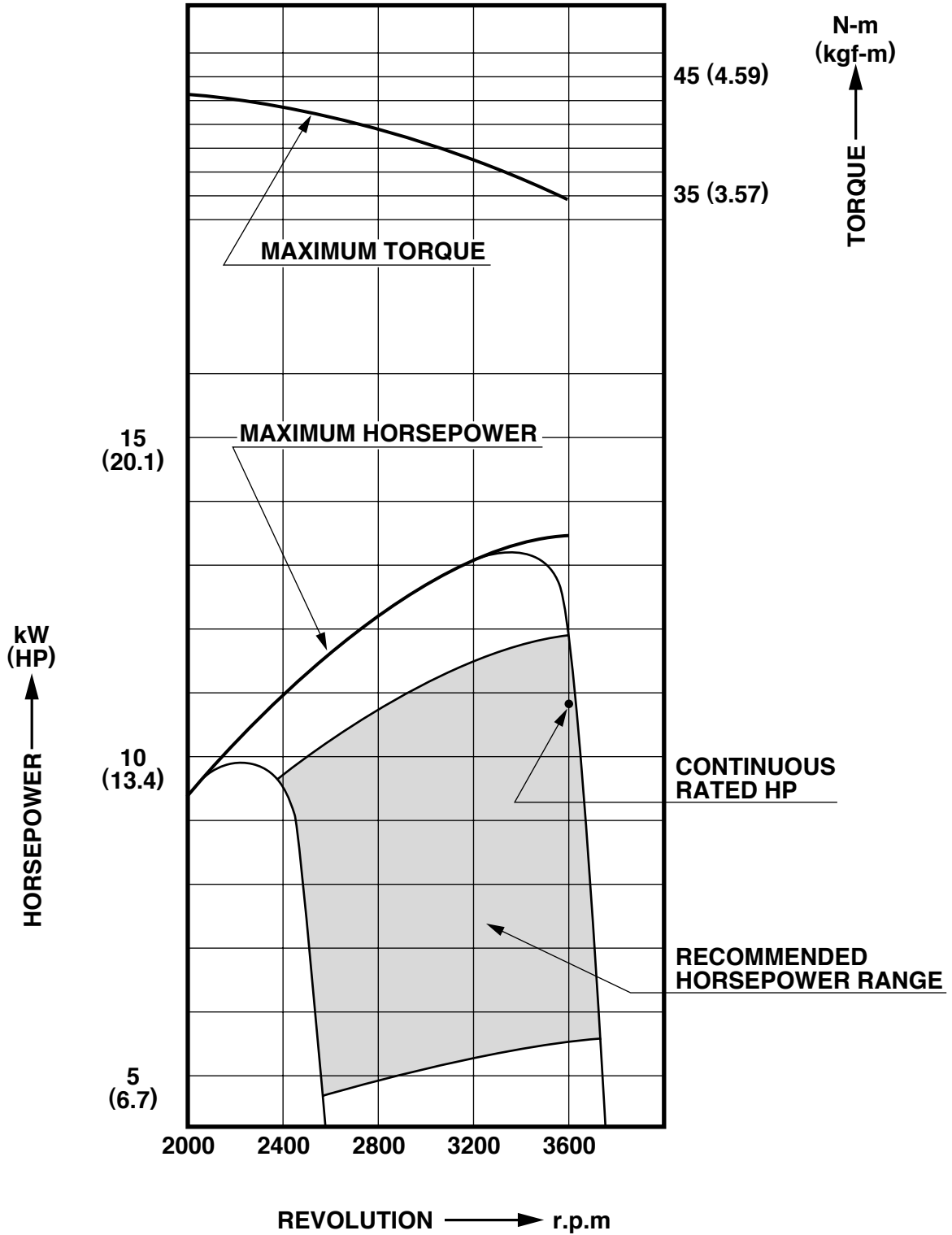

# EH64D

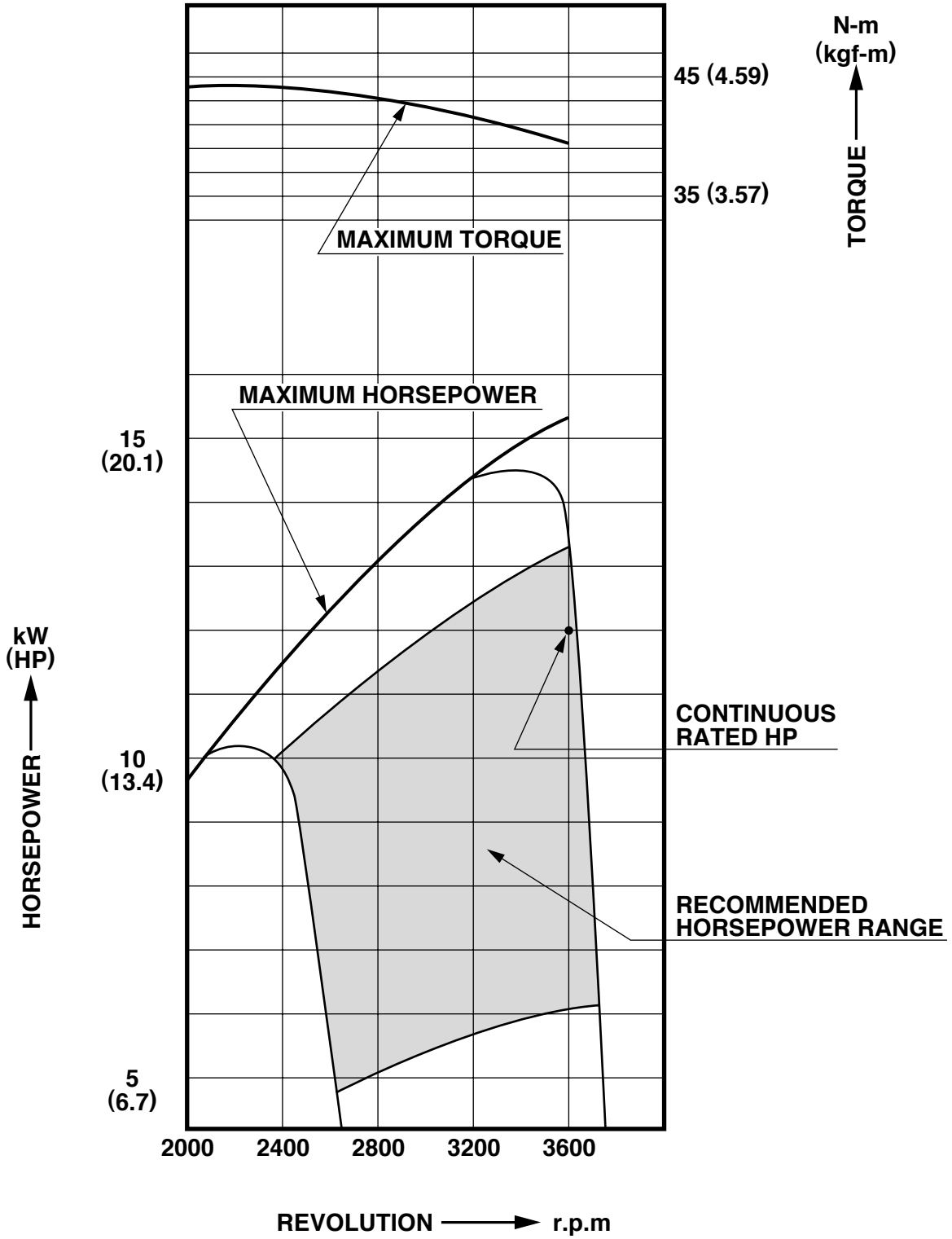

# EH65D

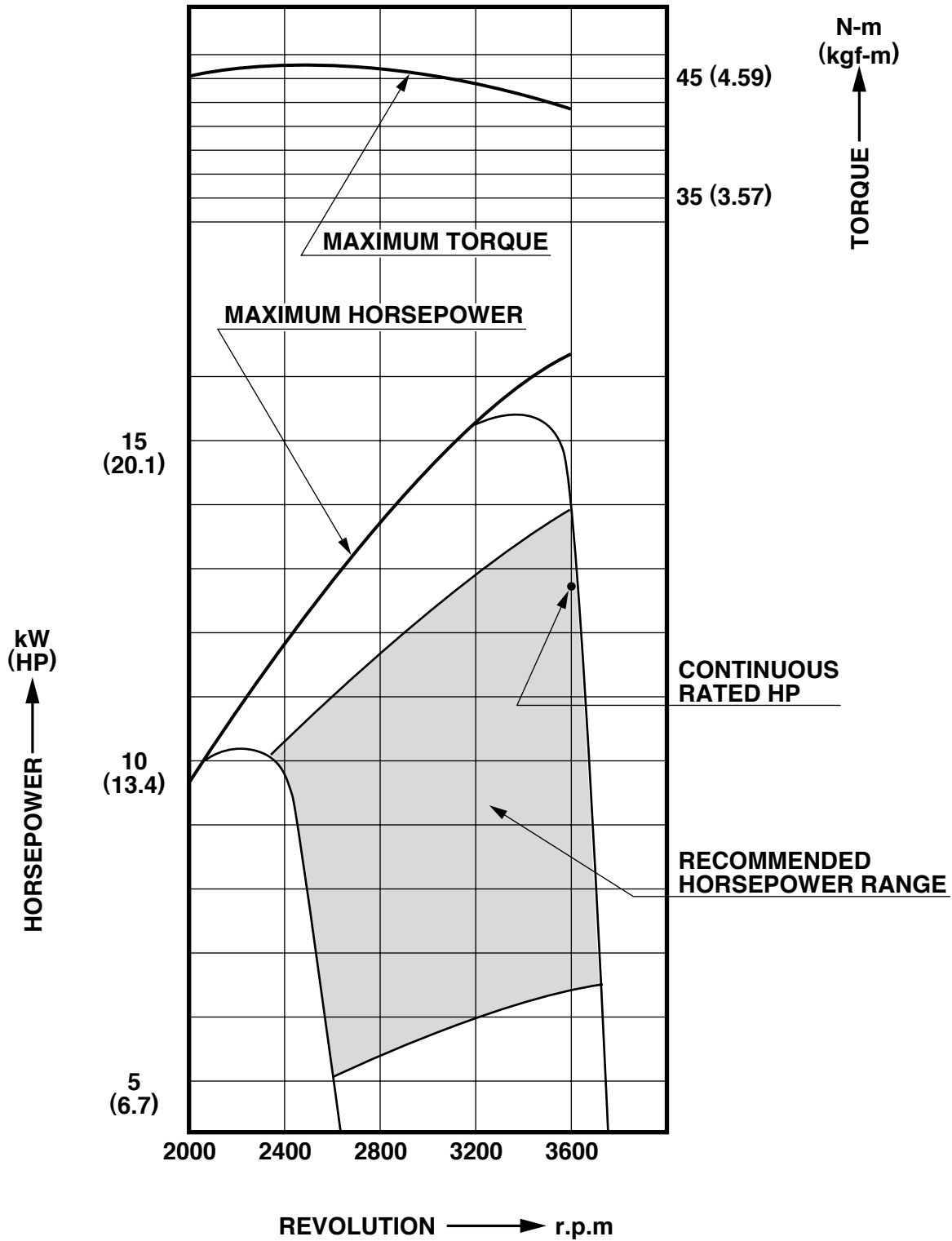



# EH72D

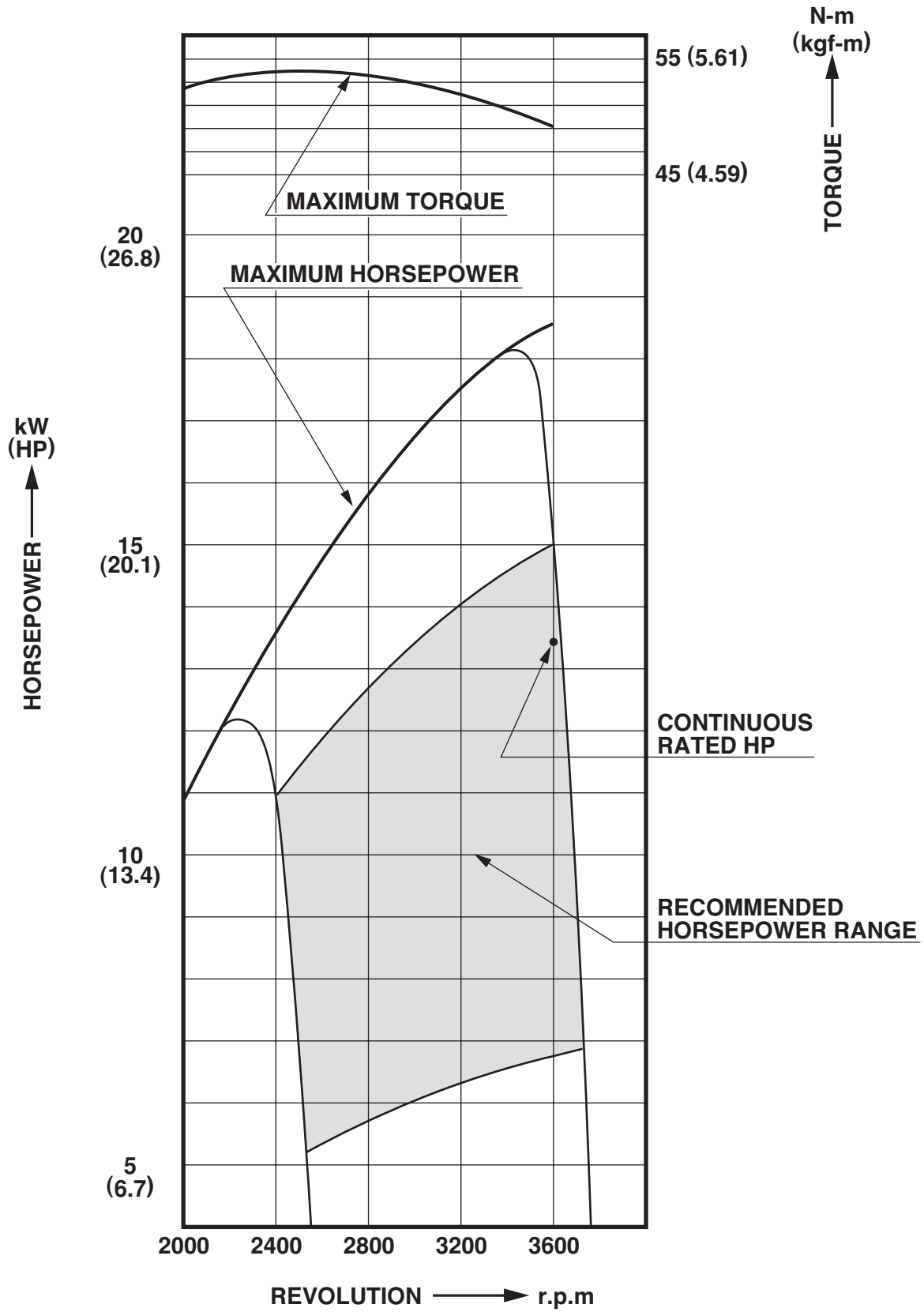

## 3. FEATURES

### Highly rigid structure

- High-carbon steel, forged crank shaft
- Light-weight , tough alminum forged connectiong rod
- Ball-bearing
- Special cast iron cylinder liner

### Long-lasting structure

- Forced pressure lubrication of crankshaft by directly connected trochoid pump
- Standard equipped oil cooler ensures a good lubrication environment
- Ball bearing installed in the throttle bearing of the carbureter

### Reliability

- Unusually high dust proofing by a double compartment air cleaner and inner vent type carbureter
- Carbureter equipped with acceleration pump, and receives excellent throttle response.
- A fine distribution suction pipe and effective combustion chamber shape provide greater cubustion stability and reduced gas emissions

### Compact

- Center height 133.3mm and 25HP
- 90° V2 cylinder built in crankcase

## 4. GENERAL DESCRIPTION OF ENGINE COMPONENTS

ROBIN EH63D/64D/65D/72D engine is air-cooled, 4-stroke, twin-cylinder, OHV arrangement gasoline engine. The twin-cylinder is located in the angle of 90 degree; #1 cylinder is in the RH side and #2 cylinder in LH side as viewed from flywheel (cooling fan) side.

### 4-1 CYLINDER AND CRANKCASE

The twin-cylinder and crankcase is single piece aluminum die-casting.

The cylinder liner, made of special cast iron, is molded into the aluminum casting.

The crankcase has a mounting surface on the output shaft side, where the main bearing cover is attached.

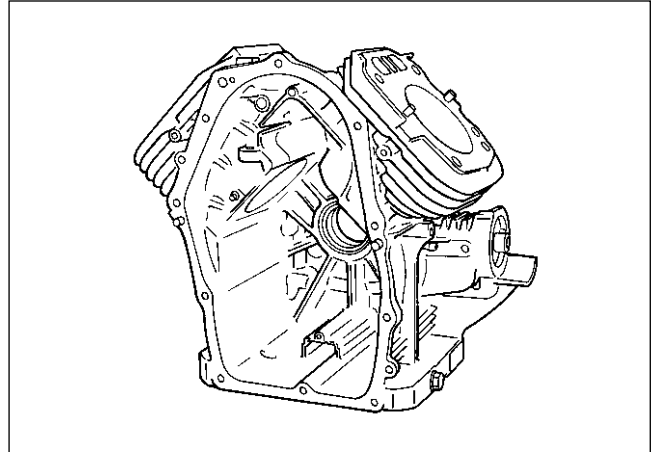

### 4-2 MAIN BEARING COVER

The main bearing cover is an aluminum die-casting, which is mounted on the output shaft side of the crankcase.

Pilots and bosses are machined on the cover for direct mounting of the engine onto such machines as generators and pumps.

It is easy to inspect inside of the engine, after removing the main bearing cover.

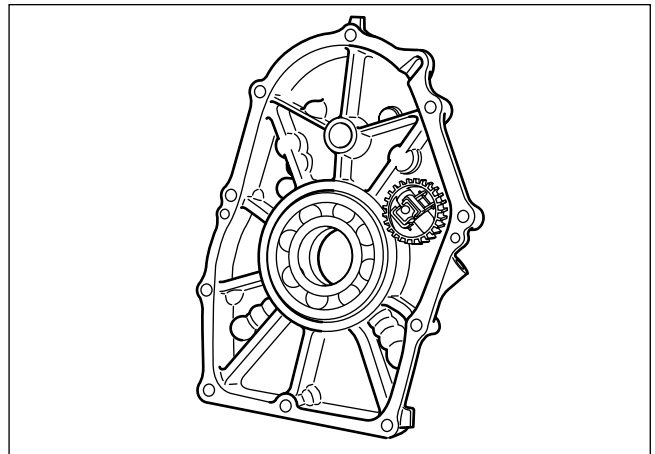

### 4-3 CRANKSHAFT

The crankshaft is forged carbon steel, and the crank pin is induction-hardened.

The output end of the shaft has a crankshaft gear pressed into position.

Engine oil passages are provided onto the journal and pin portions of crankshaft for lubrication.

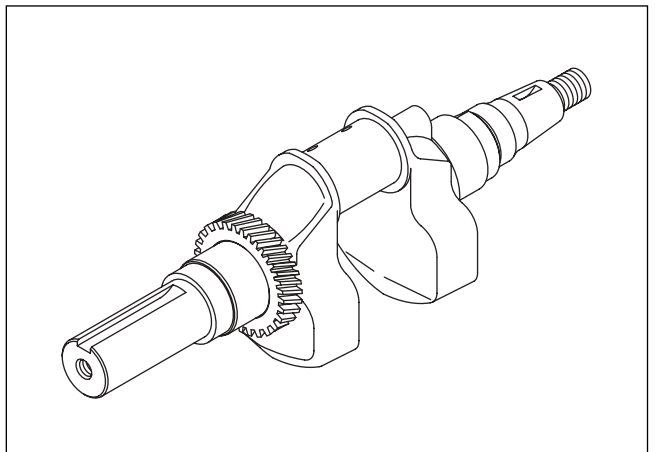

#### 4-4 CONNECTING ROD AND PISTON

The connecting rod is forged aluminum alloy, and its large and small ends function as bearings.  
 The piston is an aluminum alloy casting, and carries two compression rings and one oil ring.

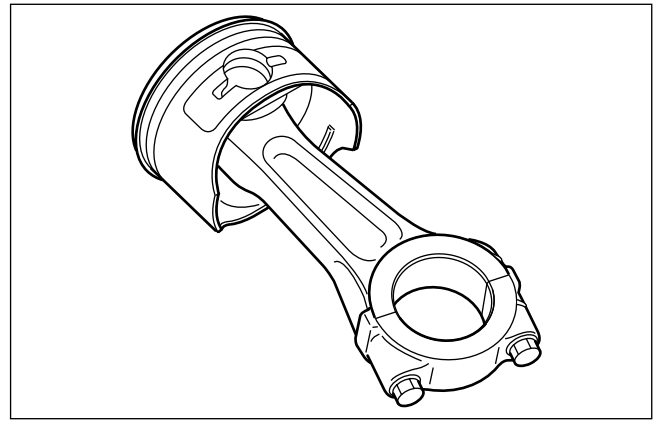

#### 4-5 PISTON RINGS

The piston rings are made of special cast iron.  
 The profile of the top ring is barrel face and the second ring has a tapered face.  
 The oil ring is designed for better sealing and less oil consumption, in combination with 3 pieces.

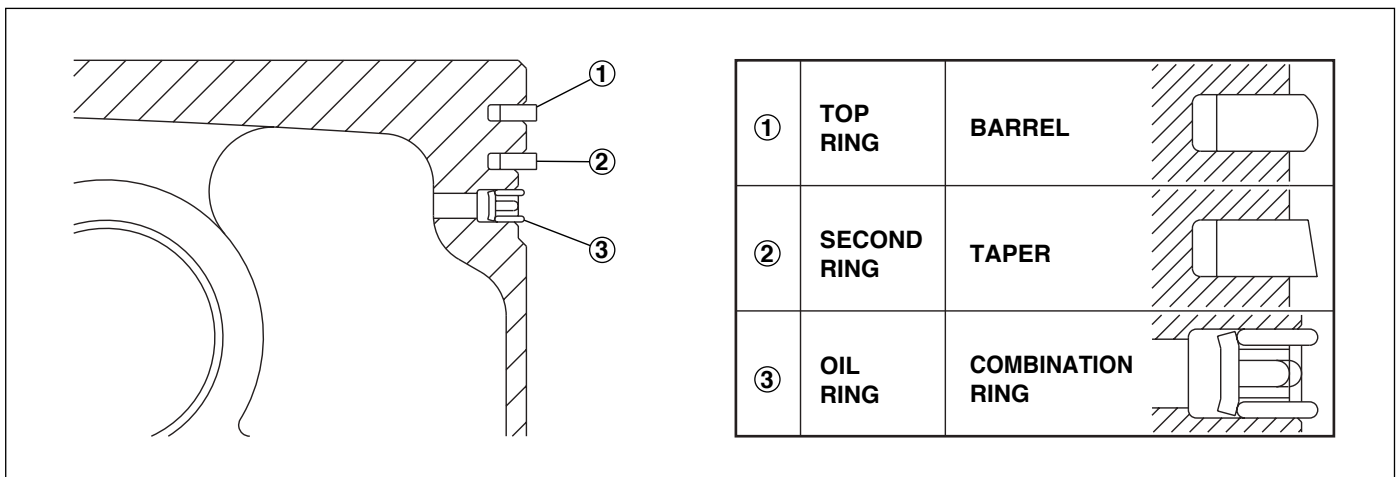

#### 4-6 CAMSHAFT

The camshaft is made of special cast iron and camshaft gears are casted together in one piece.  
 Each 2 cam robs are provided for intake and exhaust valves correspondingly.  
 Both sides of the shaft fit into the plane bearings on the crankcase and main bearing cover.

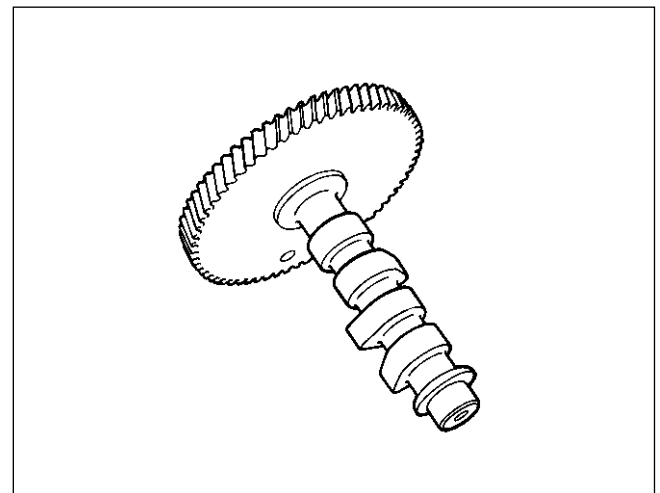

#### 4-7 CYLINDER HEAD

The cylinder head is an aluminum die-casting which utilizes semi-spherical type combustion chamber for the high combustion efficiency.

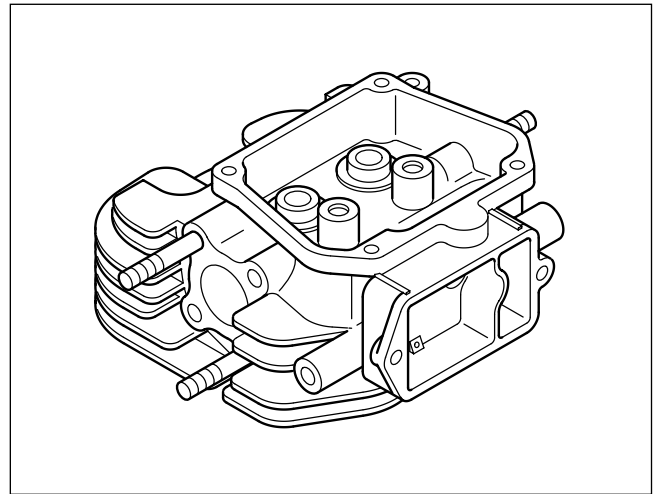

#### 4-8 VALVE ARRANGEMENT

The intake valve is located on flywheel side of the cylinder head.

The cooling fins and passages design lead cooling air to the exhaust valve area for the optimum cooling.

Hard alloy valve seats are molded in the cylinder head.

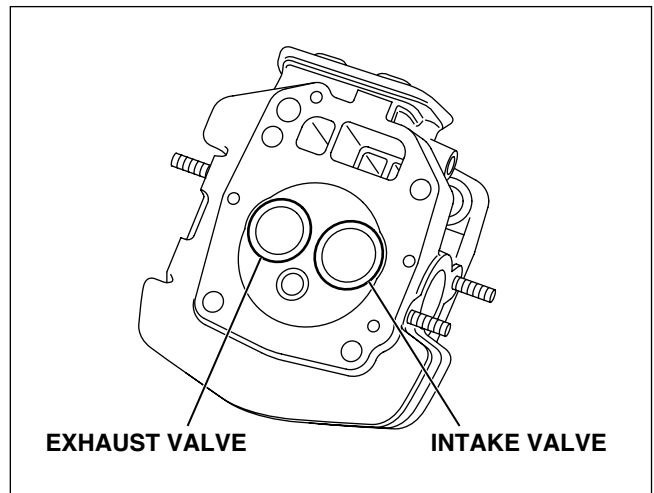

#### 4-9 GOVERNOR SYSTEM

The governor is a centrifugal flyweight type which ensures constant operation at the selected speed against load variations.

The governor gear with governor weights is installed inside of main bearing cover and driven by the crankshaft.

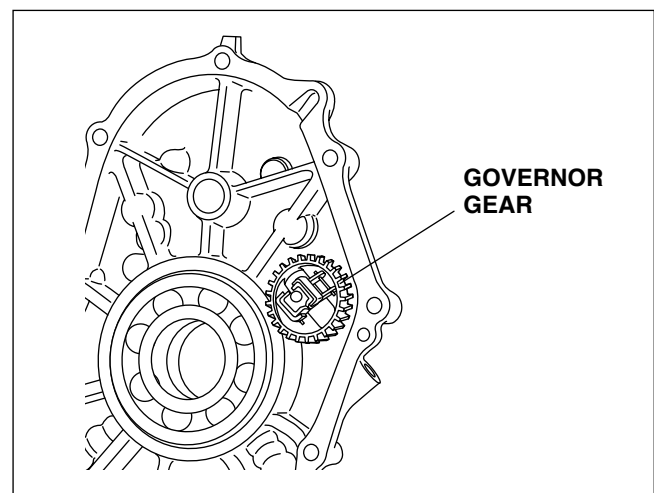

## 4-10 COOLING SYSTEM

The large fins on the flywheel provide sufficient cooling air capacity for cylinder and cylinder head. The cylinder baffle helps the cooling air flow efficiently.

## 4-11 LUBRICATION SYSTEM

The engine is furnished with full pressure lubrication system.

The trochoid type oil pump is driven by crankshaft and delivers pressurized engine oil through the full-flow type oil filter to the journal and pin portions of crankshaft and camshaft.

## 4-12 IGNITION SYSTEM

The ignition system is a transistor controlled magneto ignition system which consists of a flywheel and an ignition coil with a built-in transistor installed onto the crankcase.

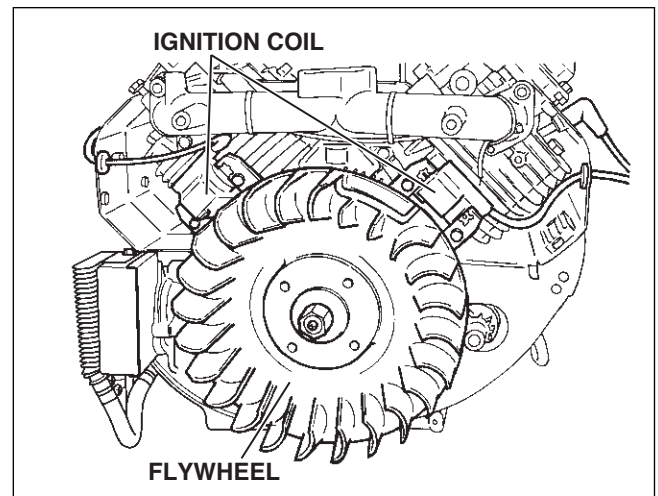

## 4-13 CHARGING SYSTEM

Multipolar charging coil is provided inside of flywheel. Charging capacity is 12V-15A or 12V-30A.

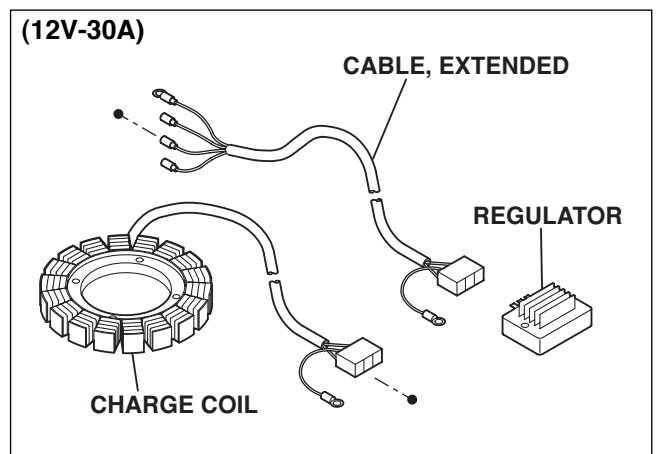
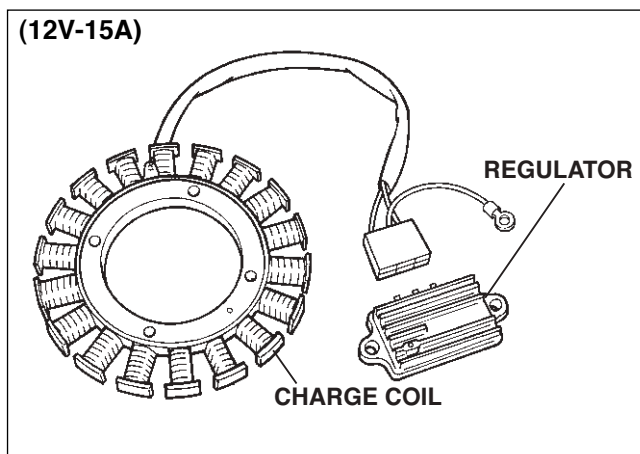

#### 4-14 CARBURETOR

The engine is equipped with a down draft carburetor that has a float controlled fuel system and a fixed main jet.

The carburetors are calibrated carefully for the sure starting, low fuel consumption and sufficient output. Fuel cut solenoid valve is provided to prevent engine running on when the key switch is turned to off.

Accelerator-pump is provided for obtaining quick and good throttle response. (EH72D)

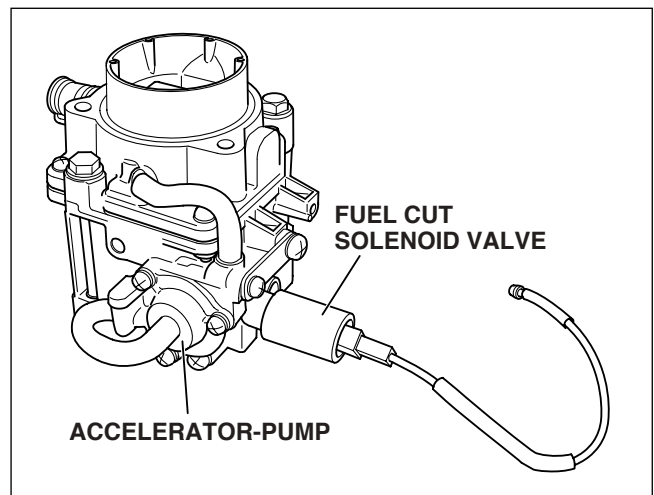

#### 4-15 AIR CLEANER

The air-cleaner is a heavy-duty type with a dual element system ; primary side is urethane foam (half-wet) and secondary side is dry type.

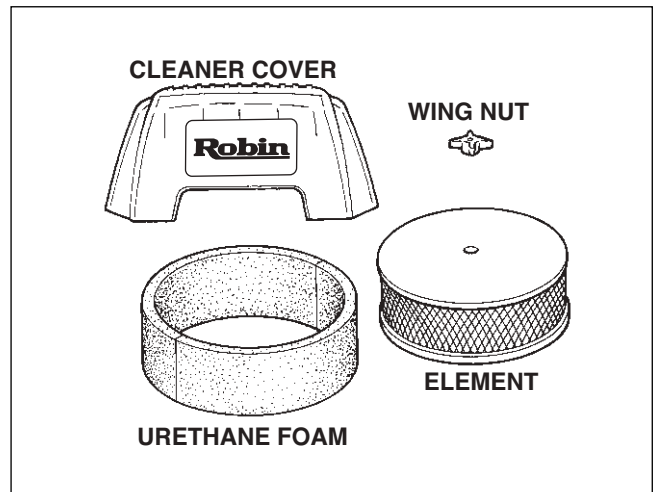

#### 4-16 FUEL PUMP

The engine is equipped with a diaphragm type fuel pump which is operated by the crankcase inside vacuum pressure.

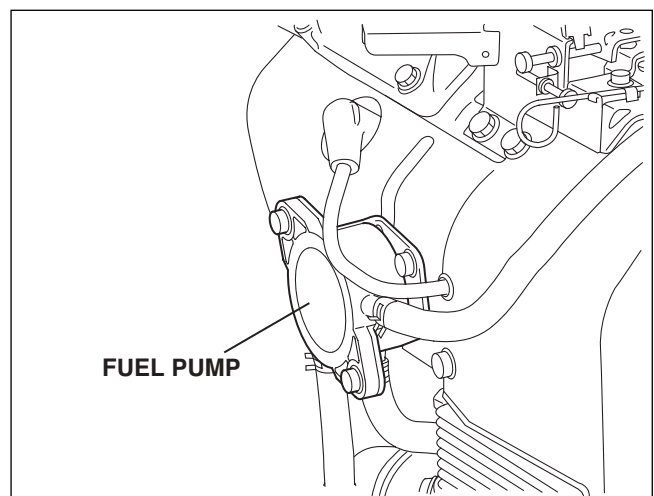

# 4-17 SECTIONAL VIEW OF ENGINE

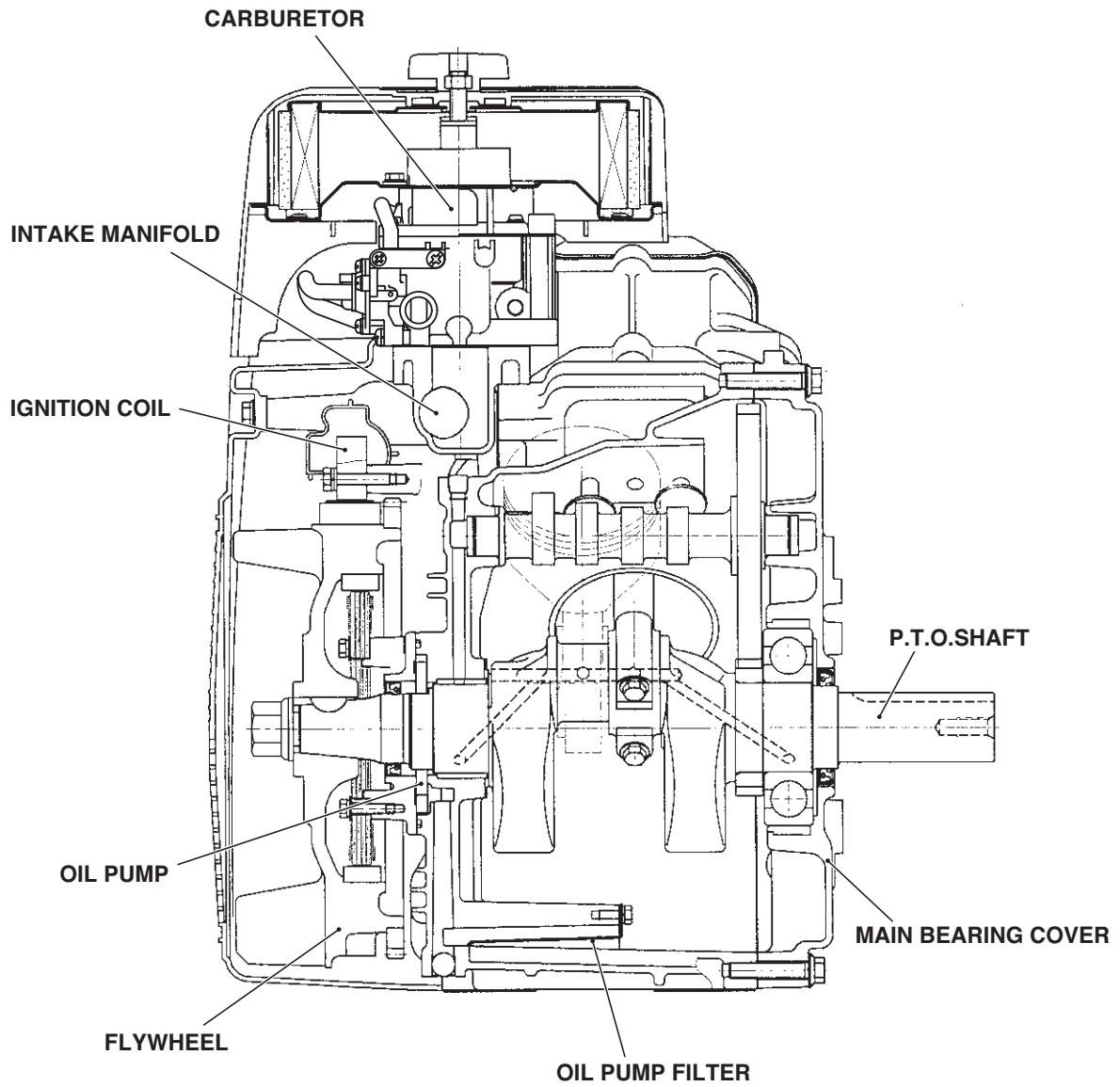



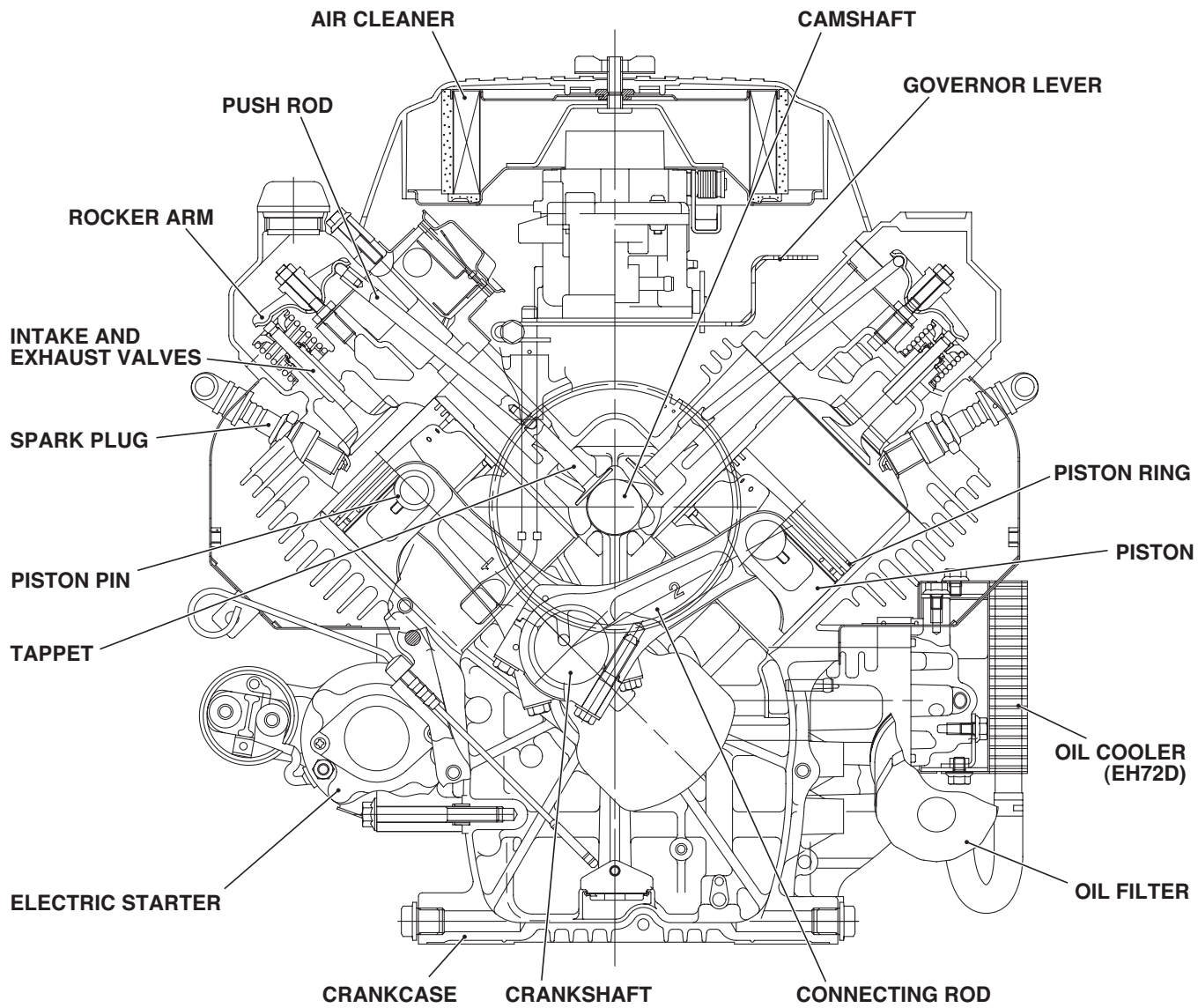

# 5. DISASSEMBLY AND REASSEMBLY

## 5-1 PREPARATIONS AND SUGGESTIONS

When disassembling the engine, memorize the locations of individual parts so that they can be reassembled correctly. If you are uncertain of identifying some parts, it is suggested that tags be attached to them.

Have boxes ready to keep disassembled parts by group.

To prevent losing and misplacing, temporarily assemble each group of disassembled parts.

Carefully handle disassembled parts, and clean them with washing oil if necessary.

Use the correct tools in the correct way.

When disconnecting electric wirings, be sure to hold and disconnect the connector housing.

## 5-2 SPECIAL TOOLS

No Special Tool is needed for disassembling and reassembling the engine.

For pulling off the flywheel, universal type puller being popular in the market place as shown in the illustration is needed.

Tool No.	Tool	Use
228-95001-17	Flywheel puller with bolt	EH63,64,65,72 / DY30,35,41,42

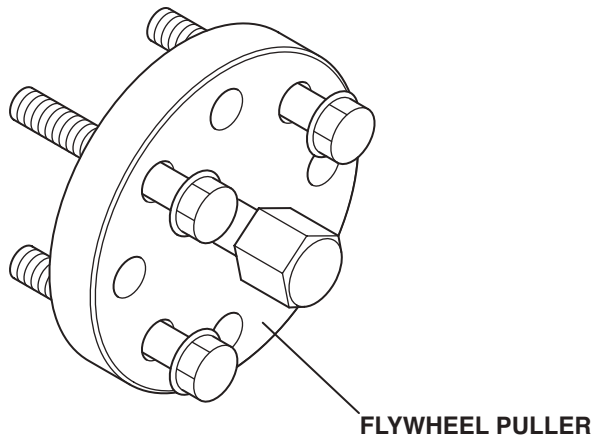

## 5-3 DISASSEMBLY PROCEDURES

Step	Parts to remove	Remarks and procedures	Fasteners
1	Engine oil drain	Drain engine oil by removing plugs located on both side of crankcase.	M14 x 12 Drain plug : 2 pcs.
2	Muffler cover		M6 x 14 Flange bolt : 4 pcs. M6 x 8 Flange bolt : 2 pcs.
3	Muffler		M8 SUS Flange nut : 4pcs.
4	Muffler bracket		M8 x 20 bolt and washer : 2pcs.

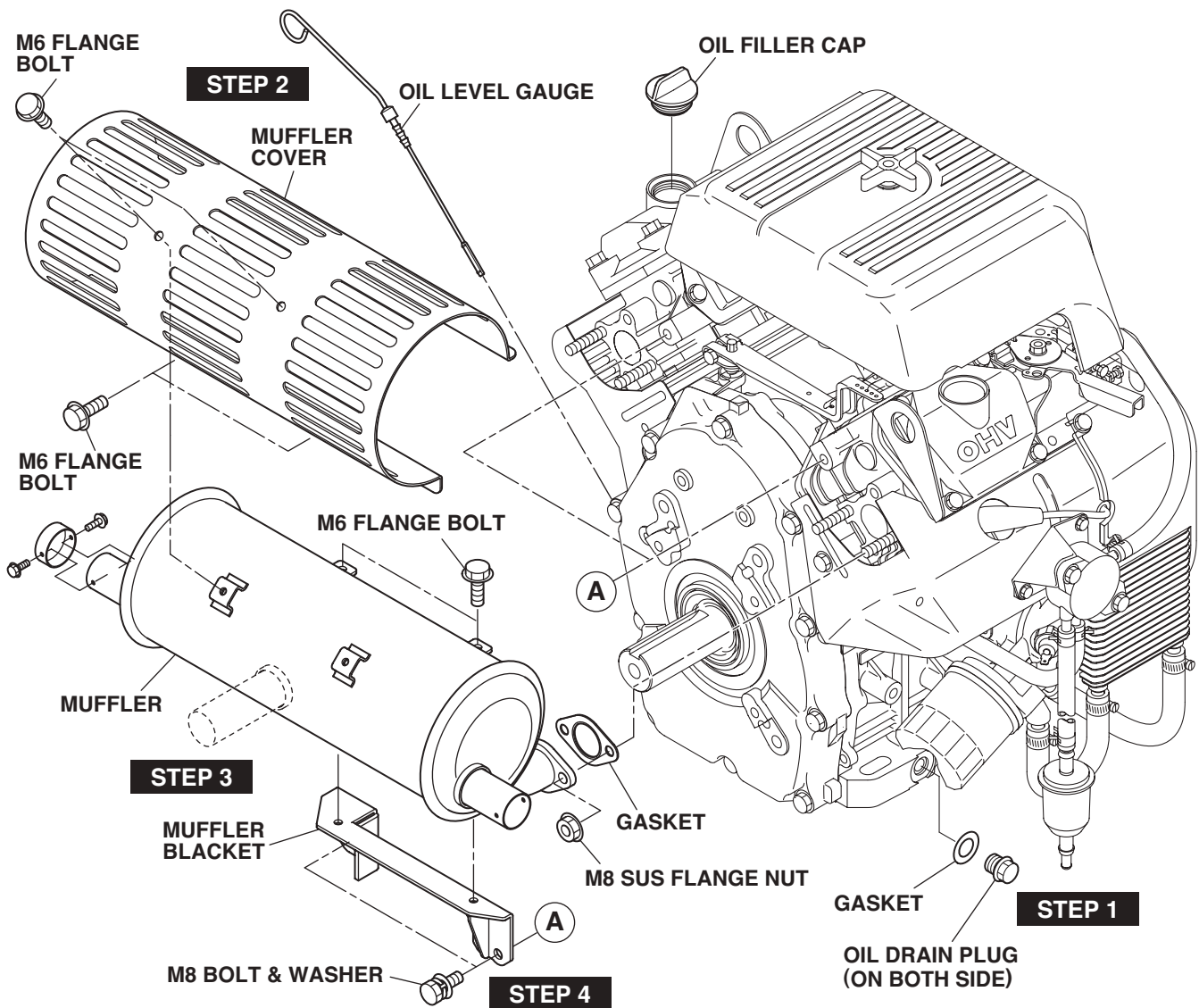

Step	Parts to remove	Remarks and procedures	Fasteners
5	Air cleaner cover and elements	Remove cleaner cover and cleaner element.	
6	Air cleaner base	Remove breather pipe from #1 cylinder head.	M6 x 12 Flange bolt : 3 pcs.

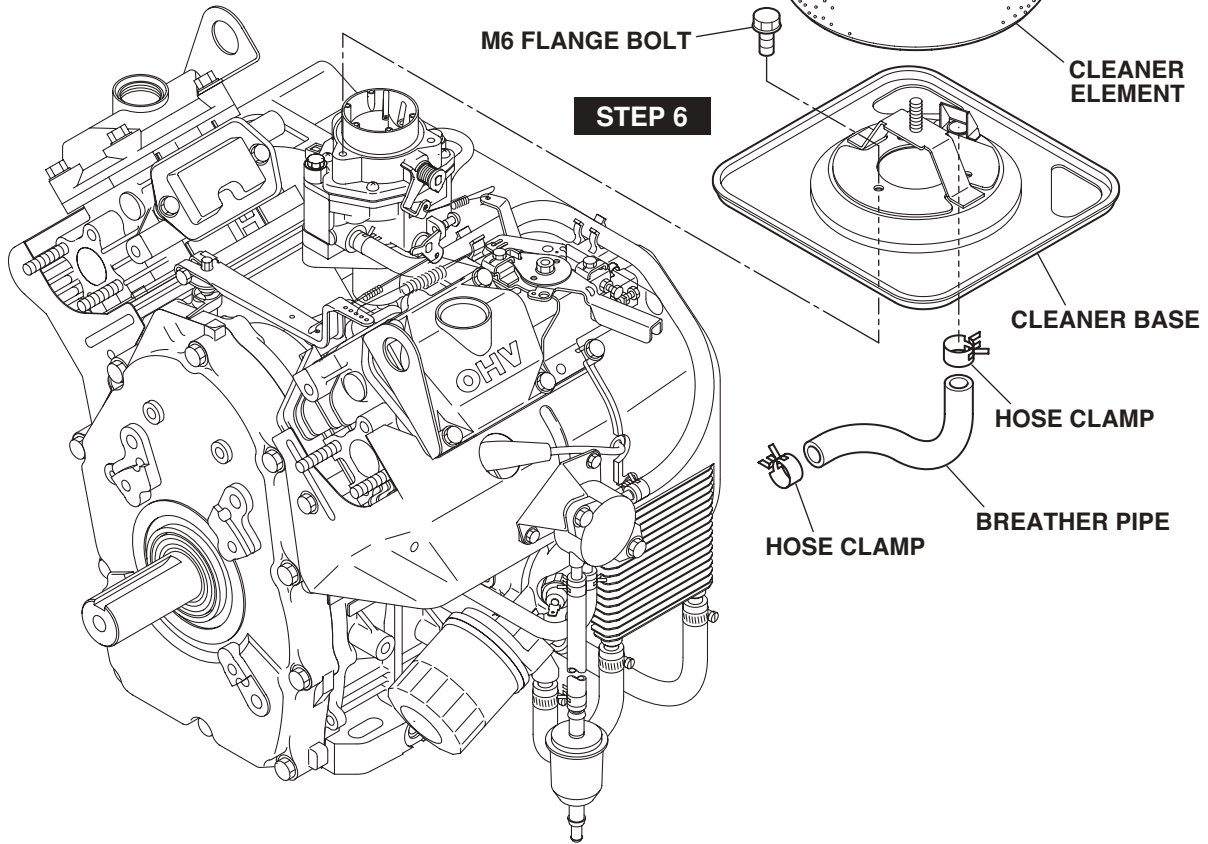
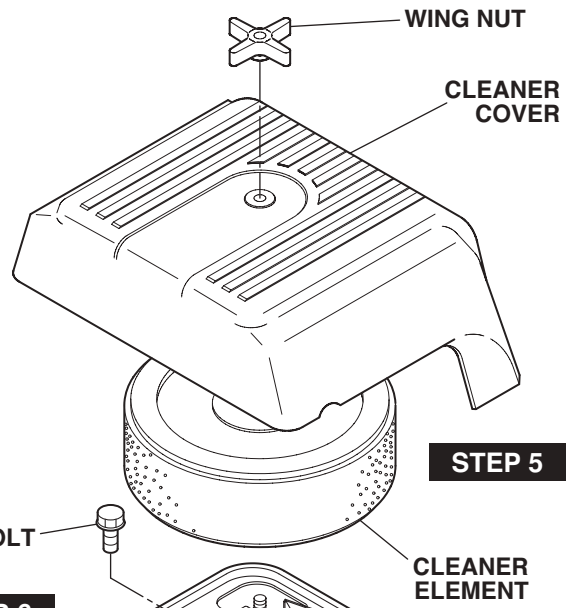
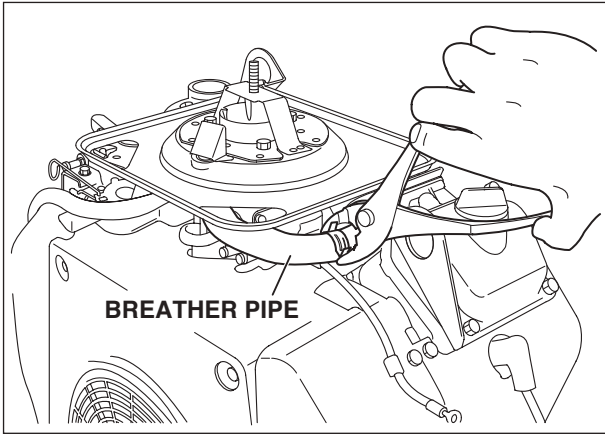

Step	Parts to remove	Remarks and procedures	Fasteners
7	Blower housing Control box	Disconnect fuel pipe and remove blower housing along with control box.	M6 x 18 Flange bolt : 2 pcs. M6 x 14 Flange bolt : 6 pcs.
8	Chock control lever and link	(1) Remove the choke knob. (2) Remove the choke control link.	M6 bolt : 1 pc.

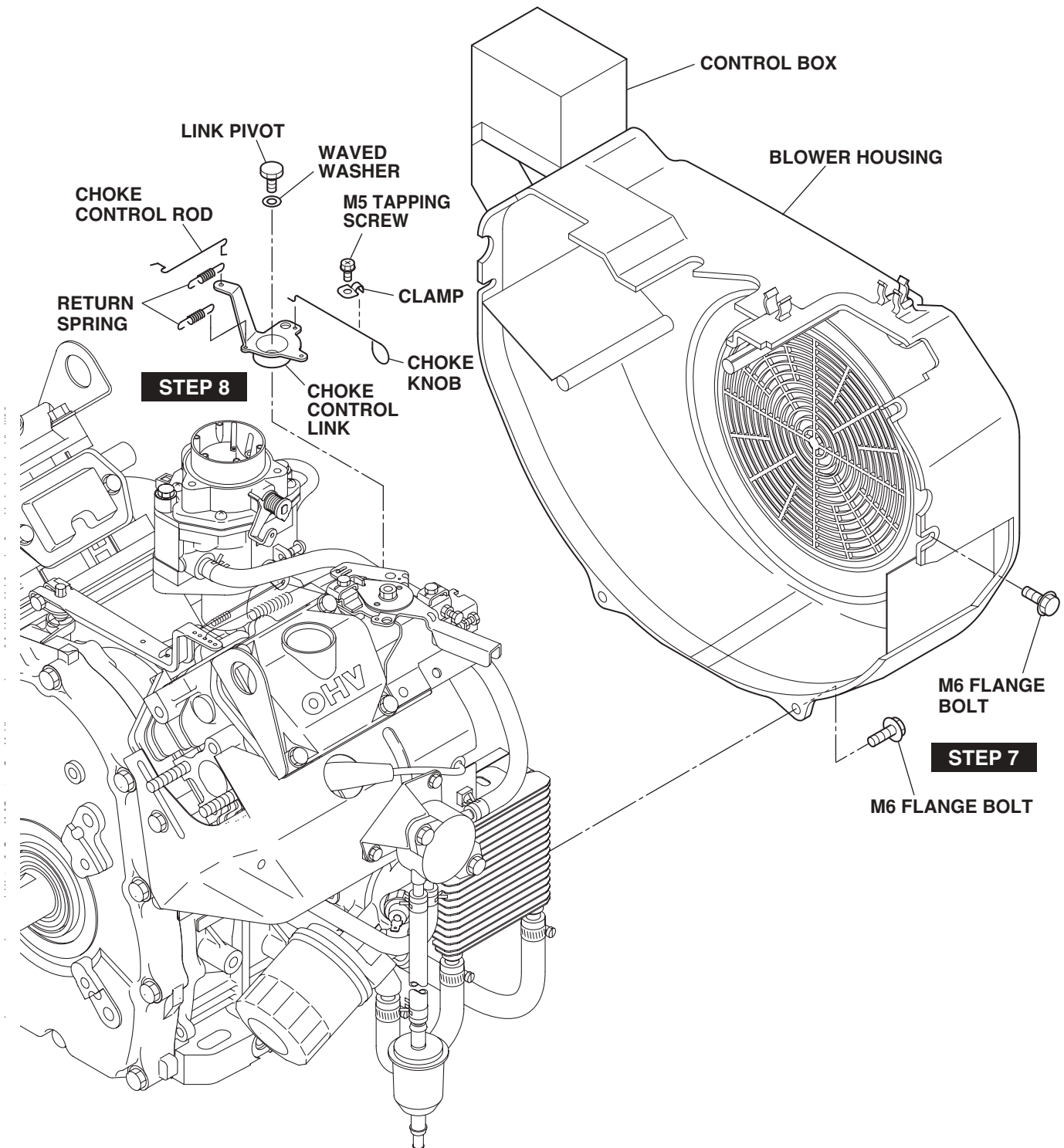

Step	Parts to remove	Remarks and procedures	Fasteners
9	Carburetor	At first remove fuel pipe. Take out carburetor along with governor rod and rod spring.	M8 x 80 Flange bolt : 2 pcs.

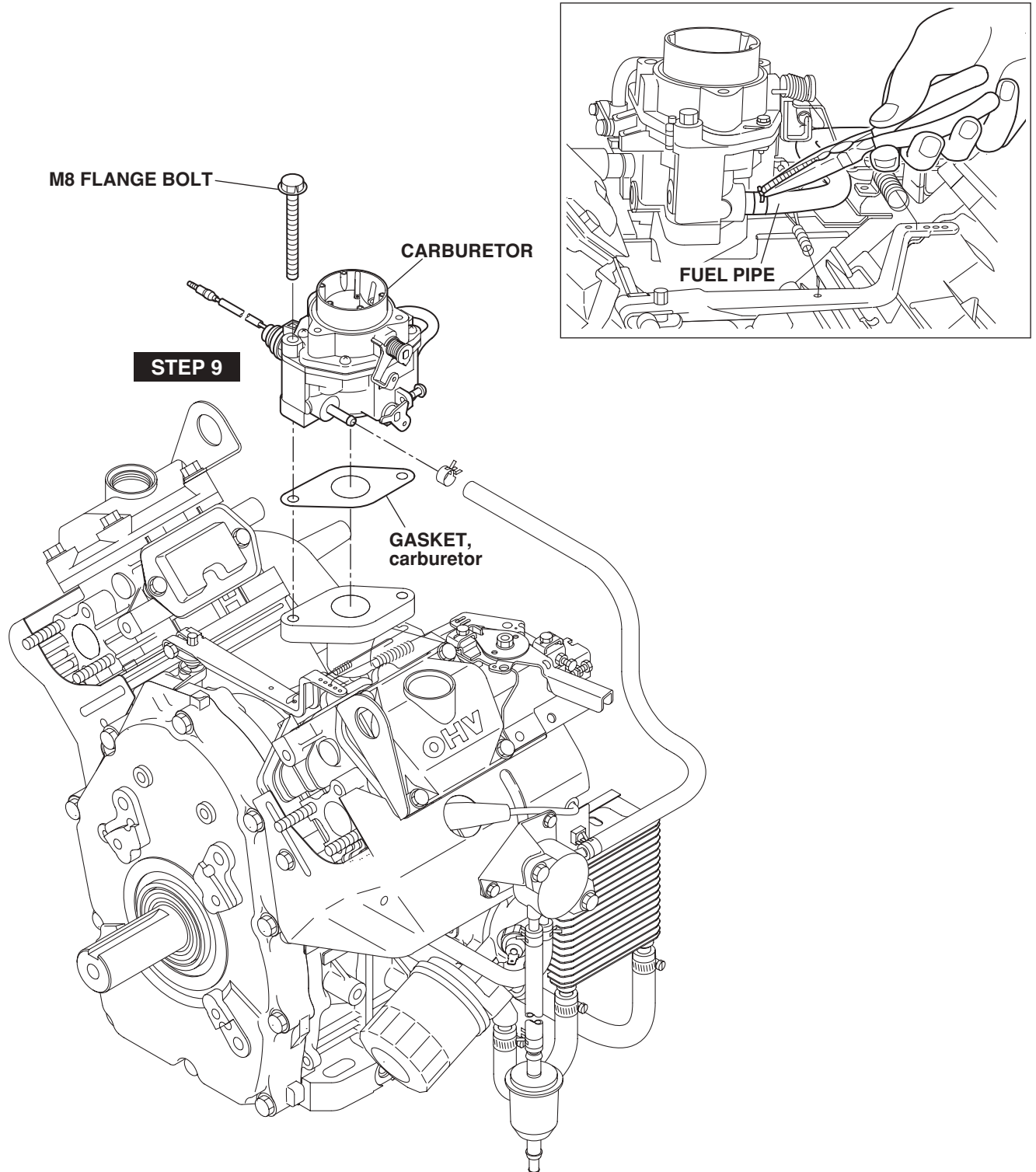



Step	Parts to remove	Remarks and procedures	Fasteners
10	Governor lever Speed control lever	1. Remove bolt and take out lever. (Make sure the fitting location of governor springs.) 2. Disassemble in the following order. (1) Governor spring (2) Self lock nut (3) Stop plate (4) Spring washer (5) Friction washer (6) Speed control lever	M6 x 12 bolt and washer : 3 pcs. M6 self-lock nut : 1 pc.
11	Speed control bracket unit		M6 x 12 Flange bolt : 2 pcs.
12	Starting motor	At first remove wiring.	M8 x 65 Flange bolt : 2 pcs.

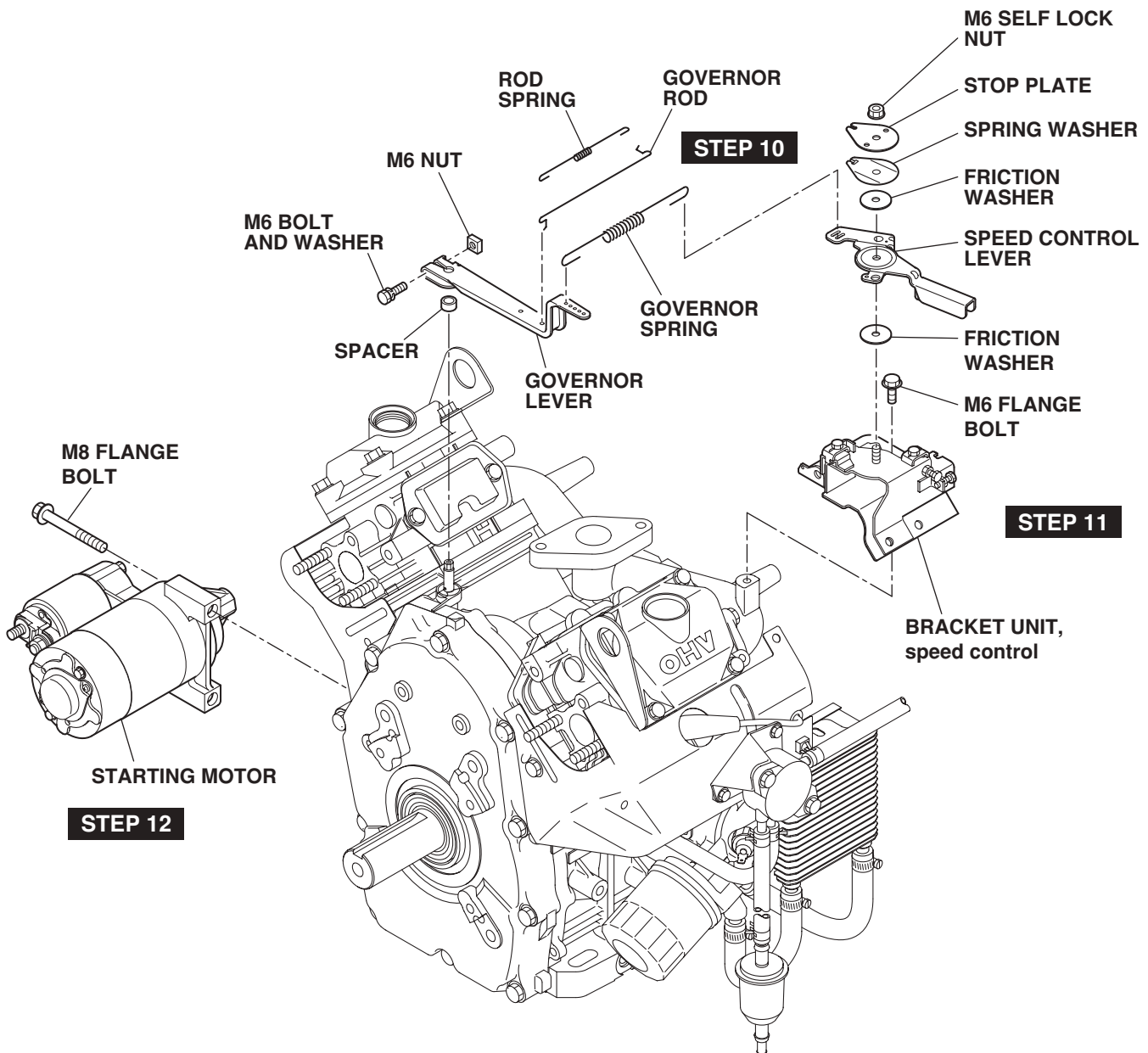

Step	Parts to remove	Remarks and procedures	Fasteners
13	Fuel pump	Remove pulse pipe at first. Remove fuel pump ASSY and detach bracket.	M6 x 12 Flange bolt : 2 pcs. M6 x 12 Flange bolt : 2 pcs.
14	Ignition coil	(1) Take out plug cap. (2) Remove ignition coil. (3) Cut out stop wire fixing bands. (4) Disconnect stop wires from ignition coil.	M6 x 25 bolt & washer : 4 pcs.

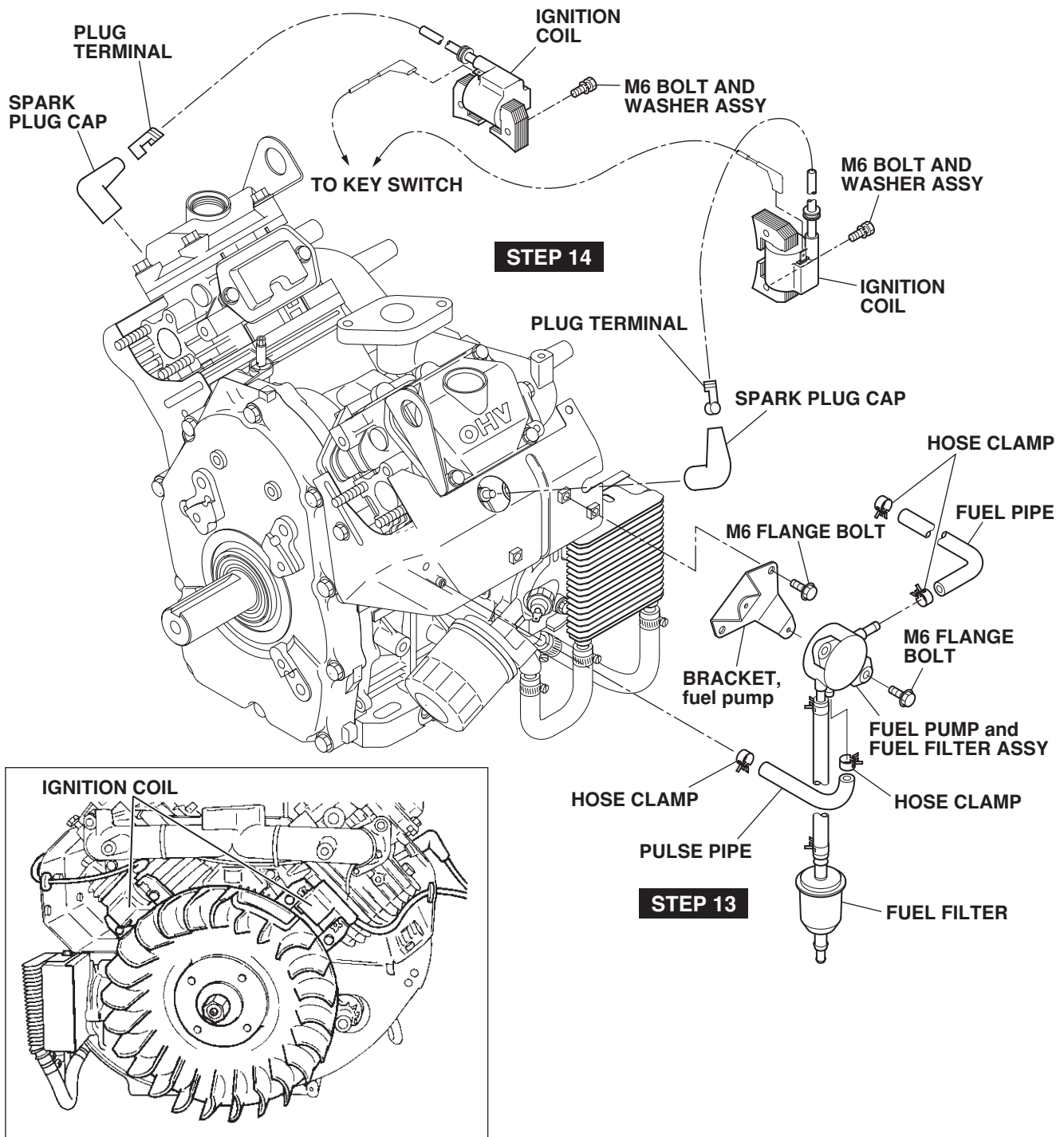



Step	Parts to remove	Remarks and procedures	Fasteners
15	Intake manifold		M8 flange nut : 4 pcs.
16	Regulator and Wire CP	Disconnect wire connector from regulator, and then remove regulator from #1 cylinder baffle.	M6 x 12 Flange bolt : 2 pcs.

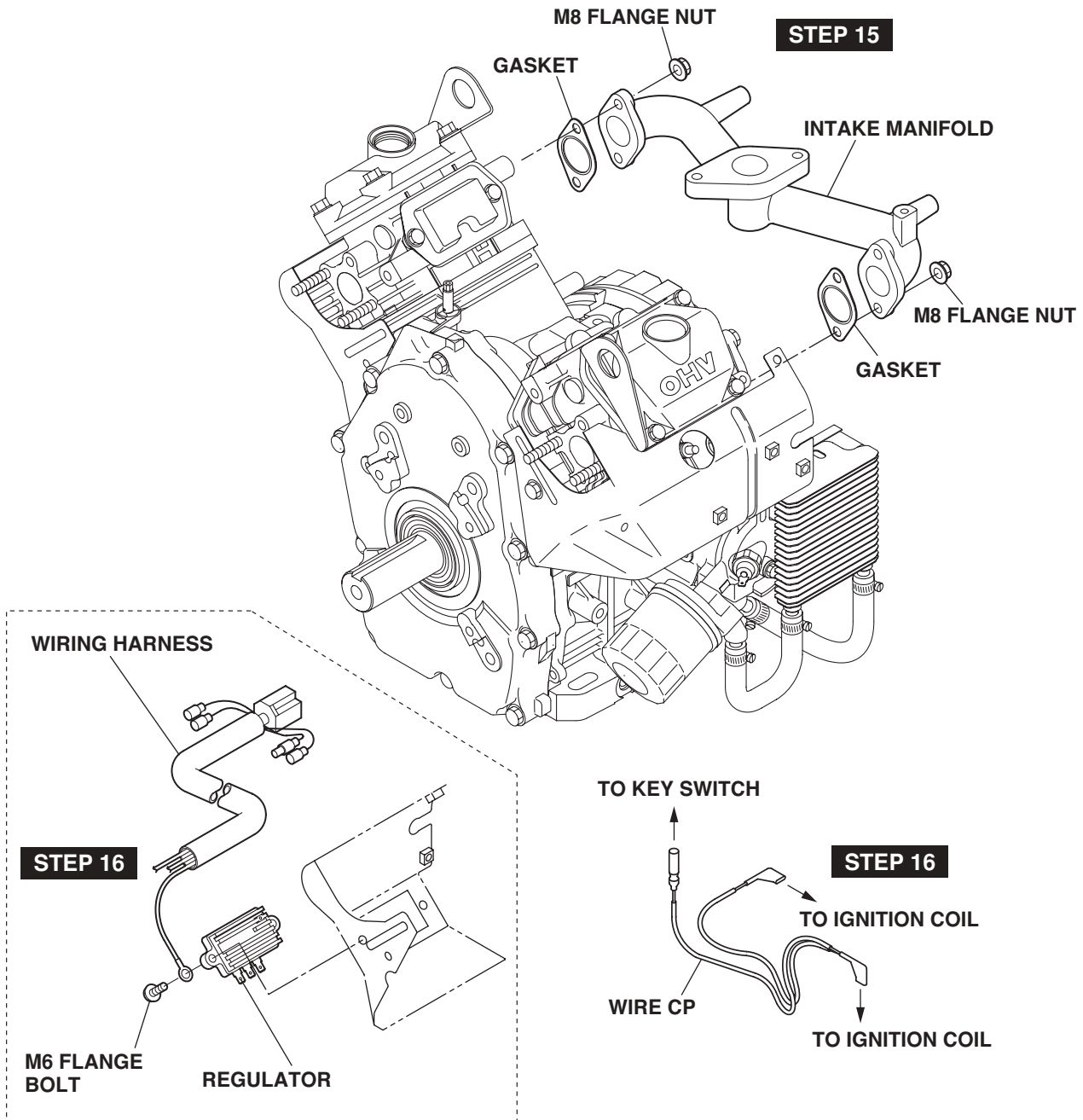

Step	Parts to remove	Remarks and procedures	Fasteners
17	Cylinder baffles (#1, #2, #3 & #4)		M6 x 12 flange bolt : 8 pcs.

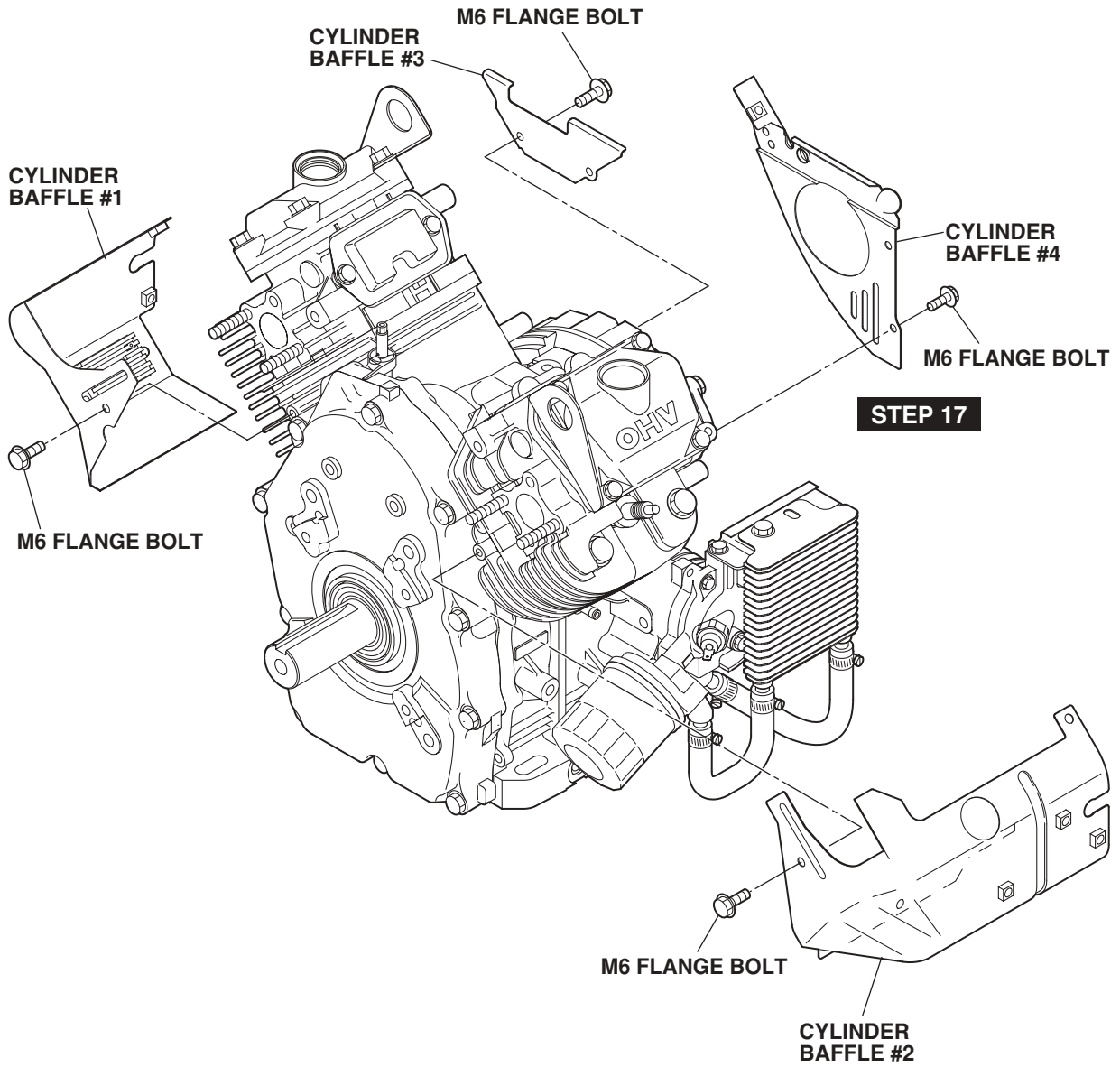

Step	Parts to remove	Remarks and procedures	Fasteners
18	Cooling fan	Remove cooling fan from flywheel.	M6 x 16 bolt & washer : 4 pcs.
19	Flywheel	Untighten flywheel nut and leave it to avoid the flywheel fell out. Take out flywheel by means of flywheel puller.	M18 Flange nut: 1 pc.
20	Charge coil		M5 x 20 bolt & washer : 4 pcs.(15A coil) M5 x 25 bolt & washer : 4 pcs.(30A coil)

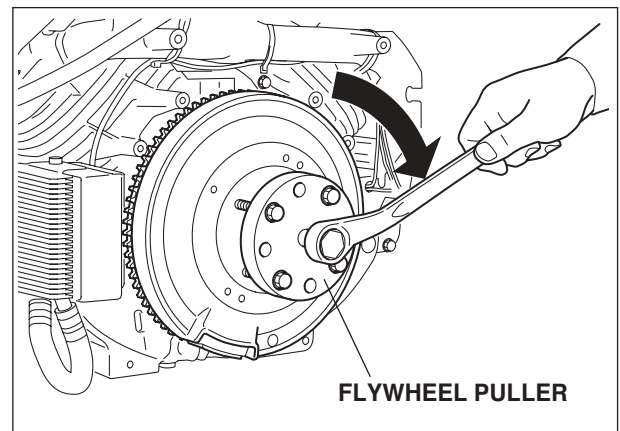
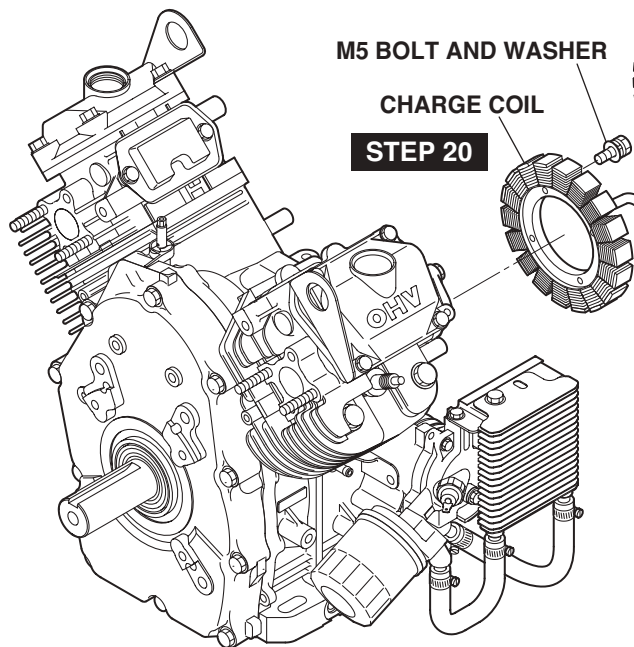
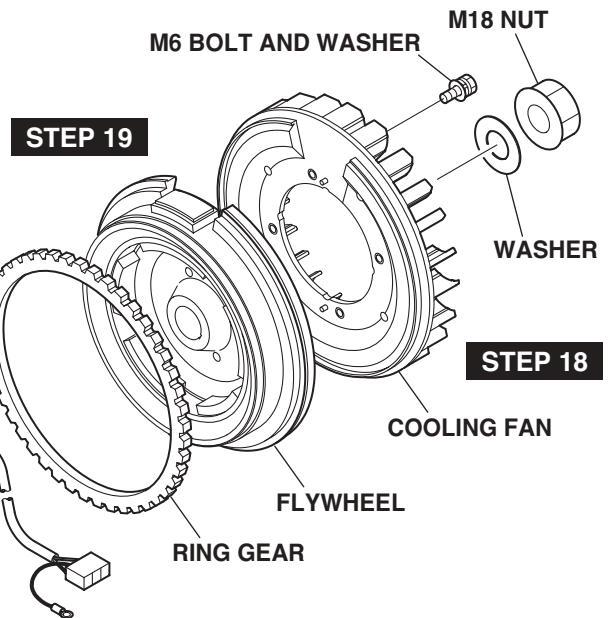
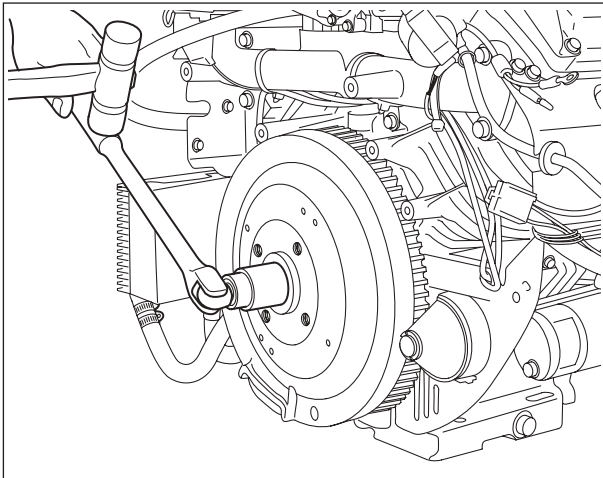

Step	Parts to remove	Remarks and procedures	Fasteners
21	Spark plug	Take care the spark plug is hot just after stopping engine.	NGK : BPR4EY
22	Oil cooler (EH72)	1. Disconnect oil hoses with clamps detached. 2. Remove oil cooler. 3. Remove bracket unit.	M6 x 12 Flange bolt : 4 pcs.

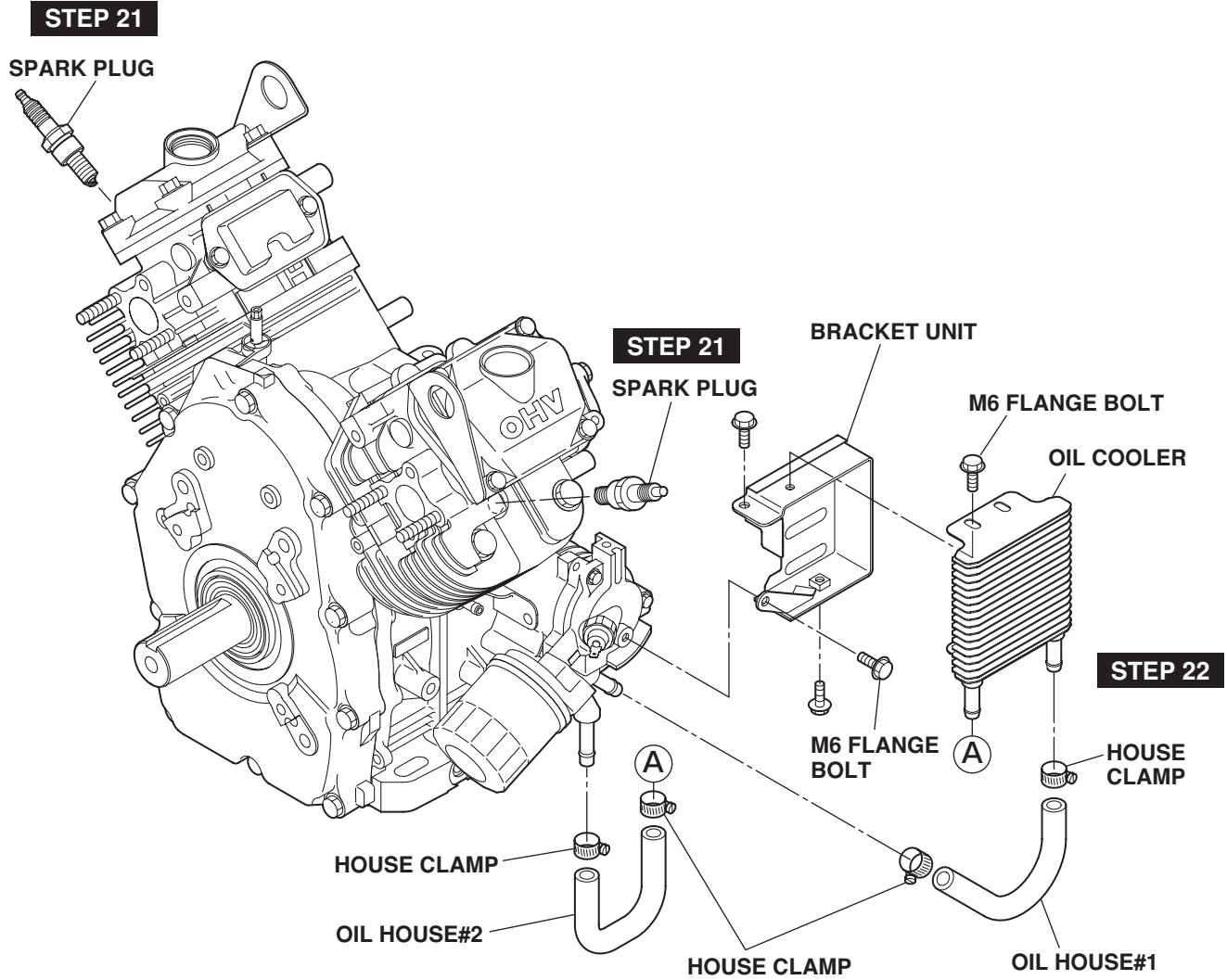

Step	Parts to remove	Remarks and procedures	Fasteners
23	Rocker cover	Remove rocker cover along with hook.	M6 x 28 Flange bolt : 8 pcs.
24	Cylinder head and Push rod 1. Bolt, pivot 2. Rocker arm	When removing "rocker arm" and "Bolt,pivot", turn and adjust flywheel at TDC with the marking "T" faced to "1" or "2" on each cylinder head. Put the marking of original position onto each push rod, rocker arm and valve for reassembly.	M10 x 65 Flange bolt : 8 pcs.

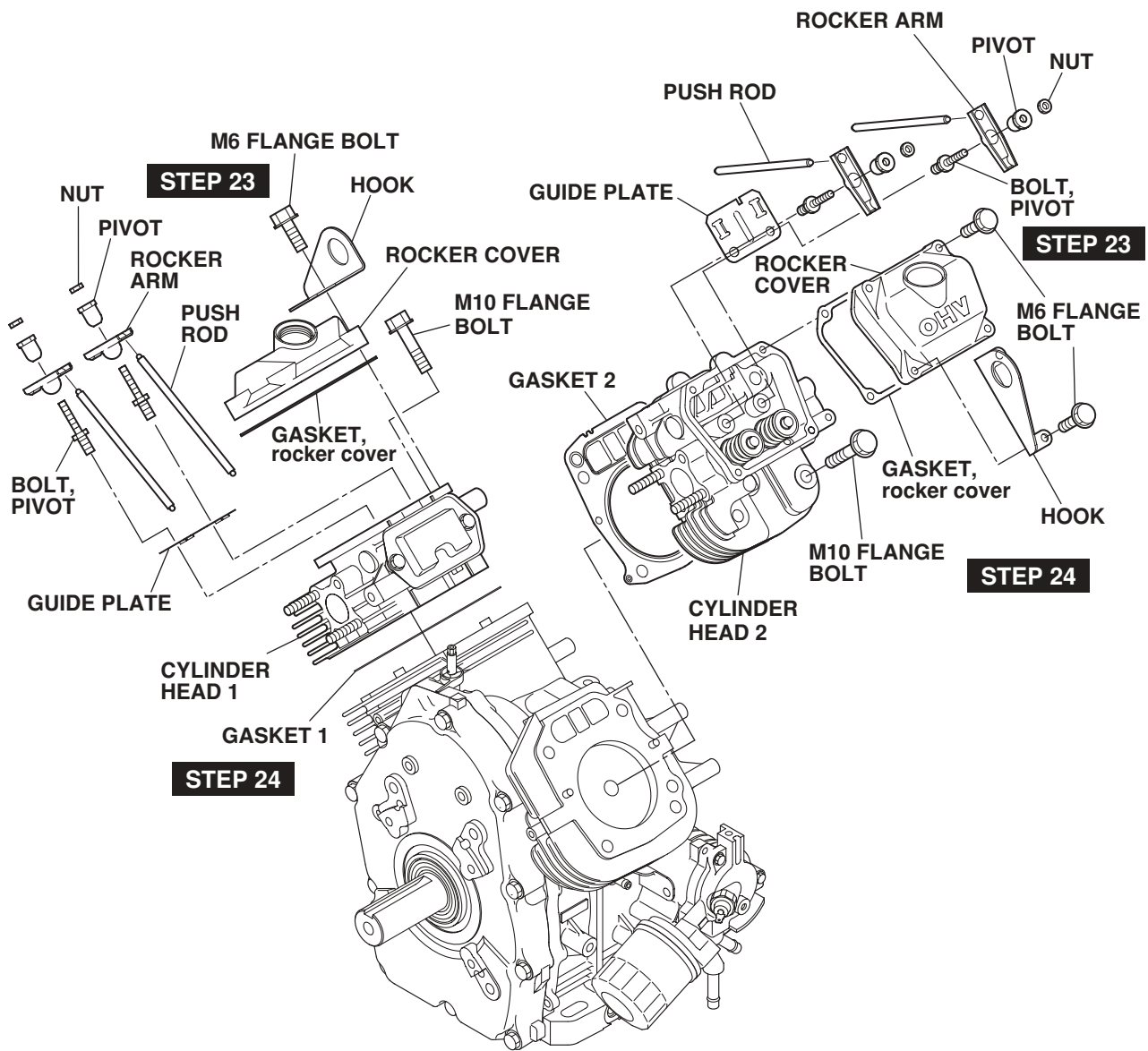

Step	Parts to remove	Remarks and procedures	Fasteners
25	Intake & exhaust valves  Breather cover Breather plate	Take out collet-valves with spring retainer depressed by hand. Take out valve springs.	M6 x 14 Flange bolt : 2 pcs.

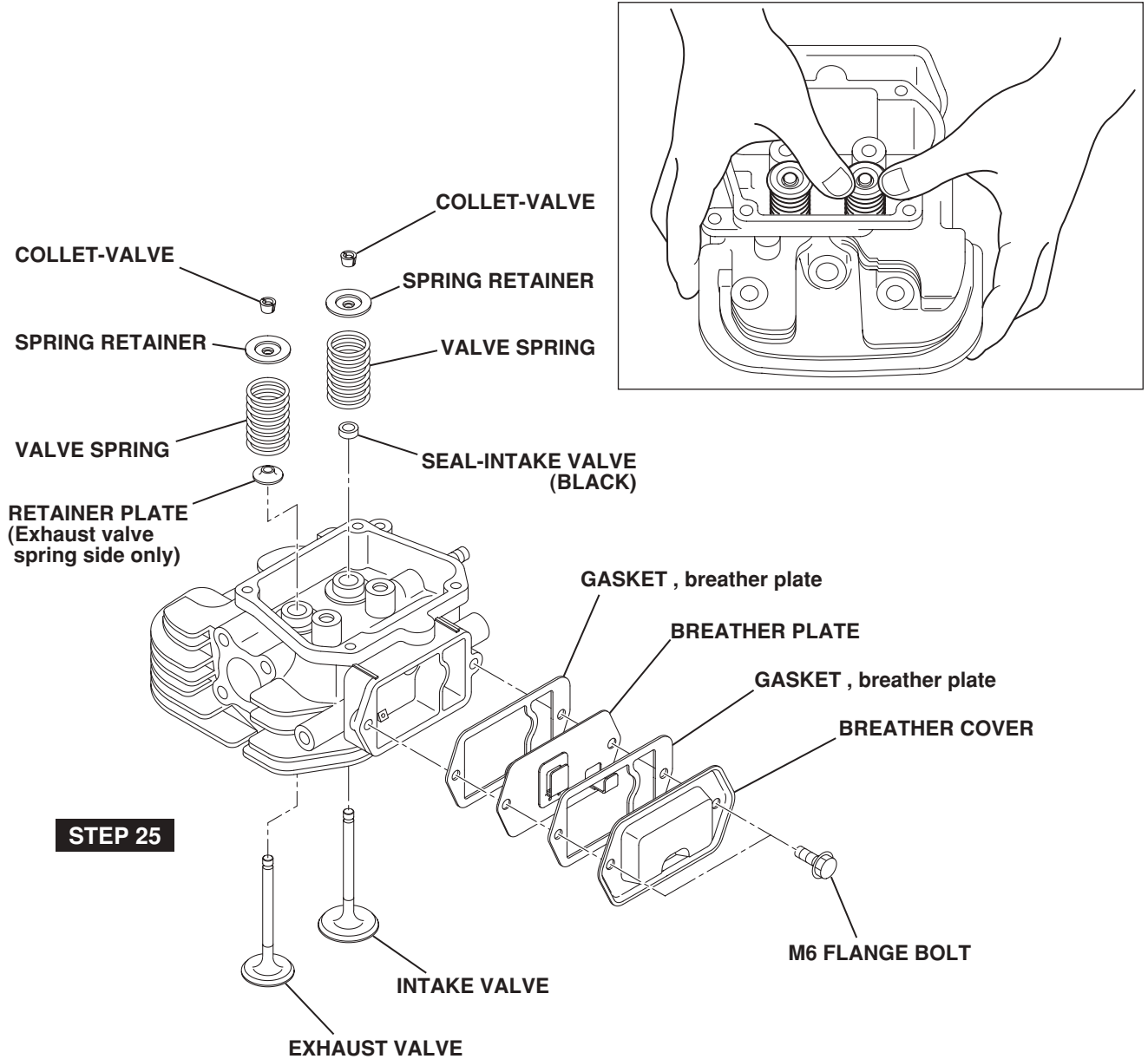

Step	Parts to remove	Remarks and procedures	Fasteners
26	Main bearing cover	Take out key from PTO shaft. Wrap PTO shaft with polyvinyl tape not to damage oil seal by key groove edge. Tapping with plastic hammer, take out main bearing cover.	M8 x 45 Flange bolt : 10 pcs.

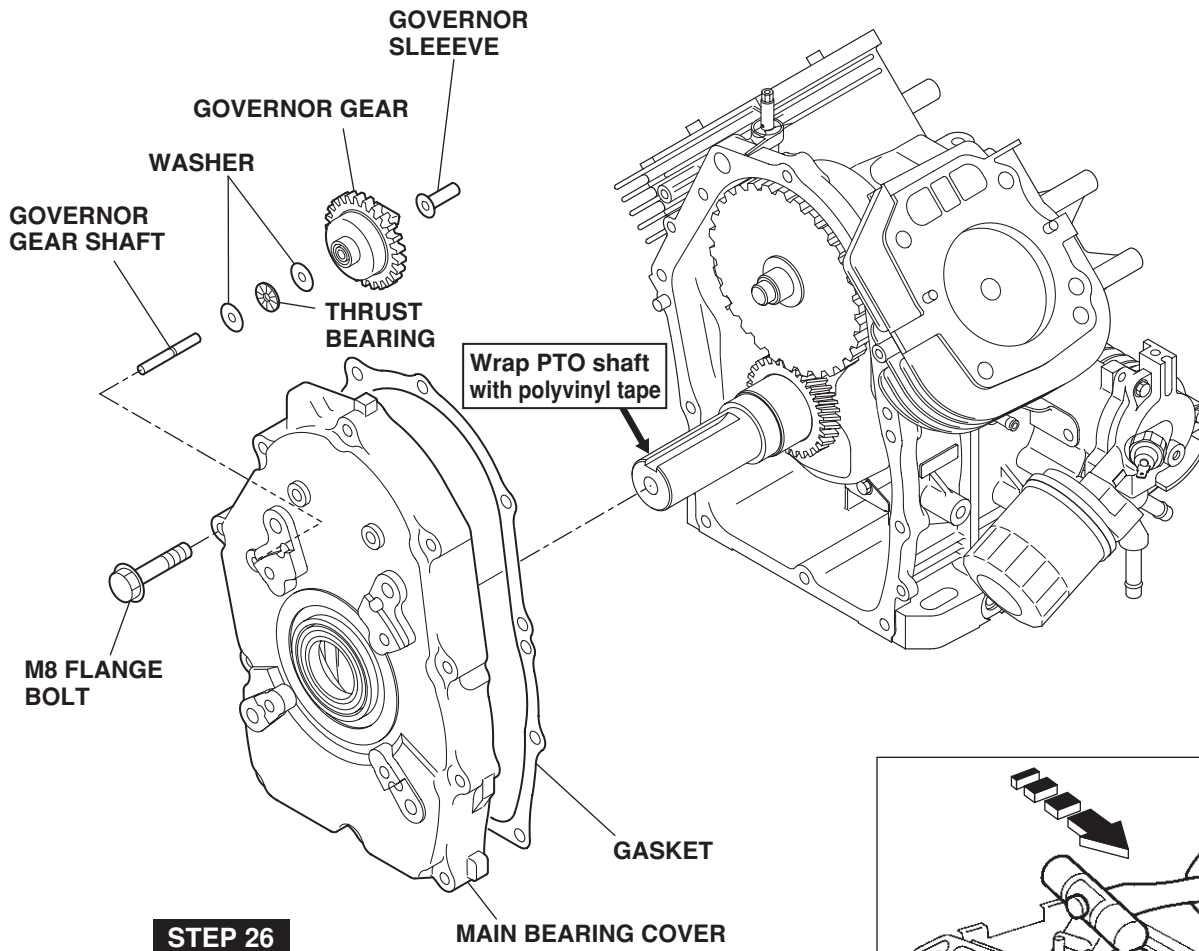

**STEP 26**

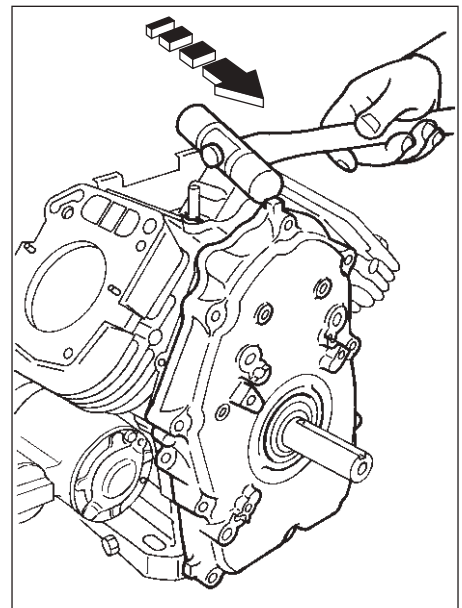



Step	Parts to remove	Remarks and procedures	Fasteners
27	Camshaft tappet	Mate the markings both on crankshaft gear and camshaft gear and then take out camshaft.  Put the marking of original position onto each tappet for reassembly.	

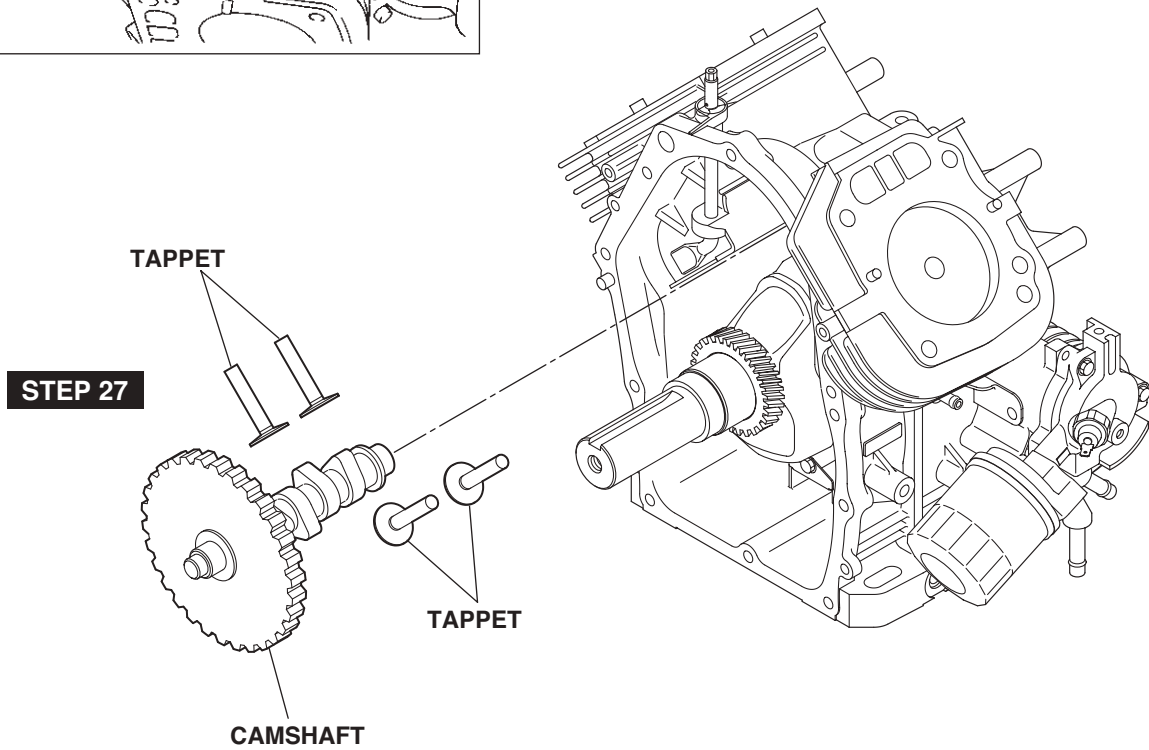
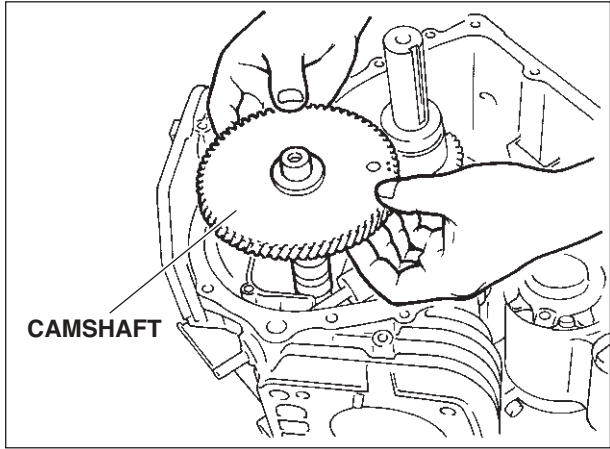



Step	Parts to remove	Remarks and procedures	Fasteners
28	Connecting rod Piston *Piston pin clip *Piston pin *Piston rings	(1) Remove connecting rod bolts. Take out connecting rod cap. (2) Push the connecting rod upwards and take out along with piston. (3) Take out clip and pull out piston pin, and then take out piston from connecting rod. (4) Remove piston rings from piston. Put the marking of original position onto each piston, ring, clip, piston pin, connecting rod and cap for reassembly.	M8 Connecting rod bolt : 4 pcs.
29	Crankshaft	(1) Remove key from crankshaft. (2) Take out crankshaft from crankcase.	

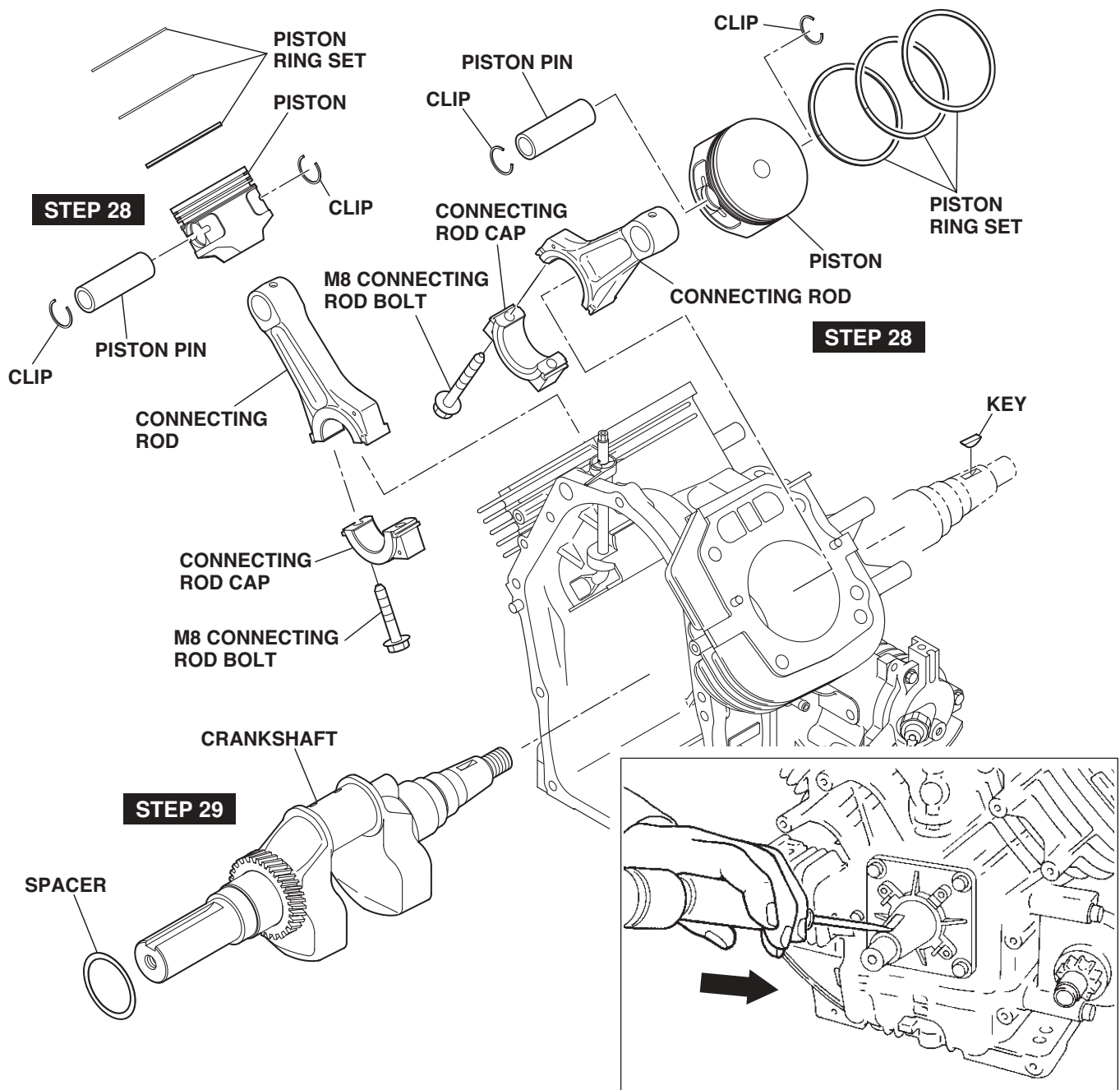

Step	Parts to remove	Remarks and procedures	Fasteners
30	Crankcase *Oil pump *Oil filter *Oil pressure switch *Oil pump filter *Oil relief spring & ball *Governor lever shaft	(1) Disconnect wire connector from oil pressure switch, and remove switch. (2) Remove oil filter and adapter. (3) Remove oil pump filter. (4) Remove oil relief plug and take out spring and ball. (Make sure spring is jumped out.) (5) Take out snap pin and pull out governor shaft. (Make sure not to loose washer.) (6) Remove oil pump cover, outer rotor, inner rotor and o-ring.	M6 x 28 Flange bolt : 3 pcs. 10-32 x 11: 1 pc. M14 x 12 M6 x 14 Flange bolt : 4 pcs.

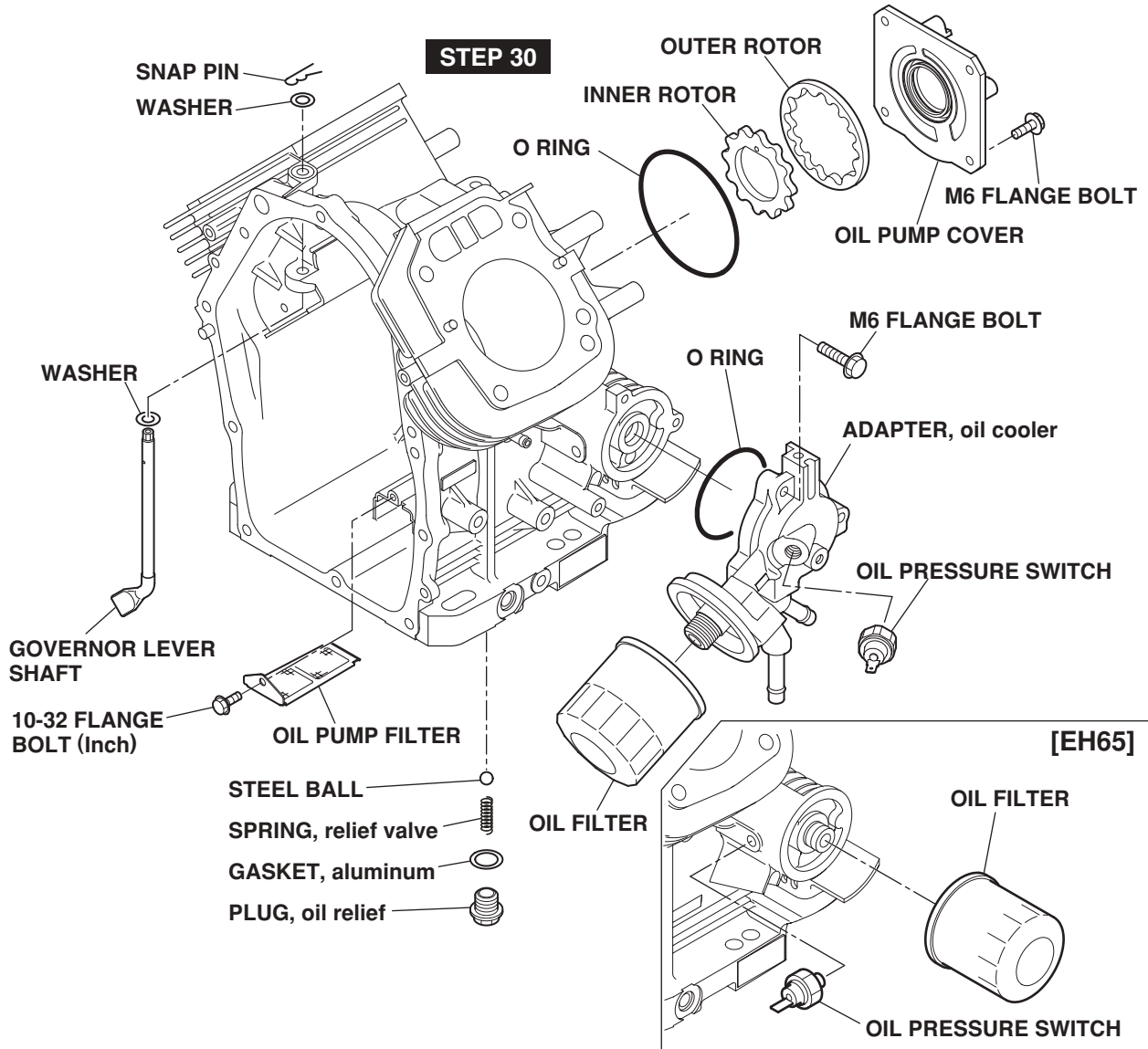

## 5-4 REASSEMBLY PROCEDURES

### 5-4-1 PRECAUTIONS FOR REASSEMBLY

- 1) Clean parts thoroughly before reassembly.  
Pay most attention to cleanliness of piston, cylinder, crankshaft, connecting rod and bearings.
- 2) Scrape off all carbon deposits from cylinder head, piston top and piston ring grooves.
- 3) Check lip of oil seals. Replace oil seal if the lip is damaged. Apply oil to the lip before reassembly.
- 4) Replace all the gaskets with new ones.
- 5) Replace keys, pins, bolts, nuts, etc., if necessary.
- 6) Torque bolts and nuts to specification referring to the "TORQUE SPECIFICATIONS".
- 7) Apply oil to rotating and sliding portions.
- 8) Check and adjust clearances and end plays where specified in this manual.
- 9) When there are many bolts, fasten opposing bolts  
(Do not fasten bolts in a circular order. In other words, after tightening one place, go to the opposite side and tighten this place next.)

### 5-4-2 Pre-assembly

#### A. CRANKCASE

- (1) Fix oil pump filter in position.
- (2) Insert ball and spring into the oil relief valve hole and tighten plug to the specified torque.

Tightening torque
14.7 - 24.5 N·m (150 - 250 kgf·cm (10.8 - 18.0 ft·lb.)

- (3) Fit governor lever shaft with clip.
- (4) Tighten oil drain plugs on both side of crankcase.

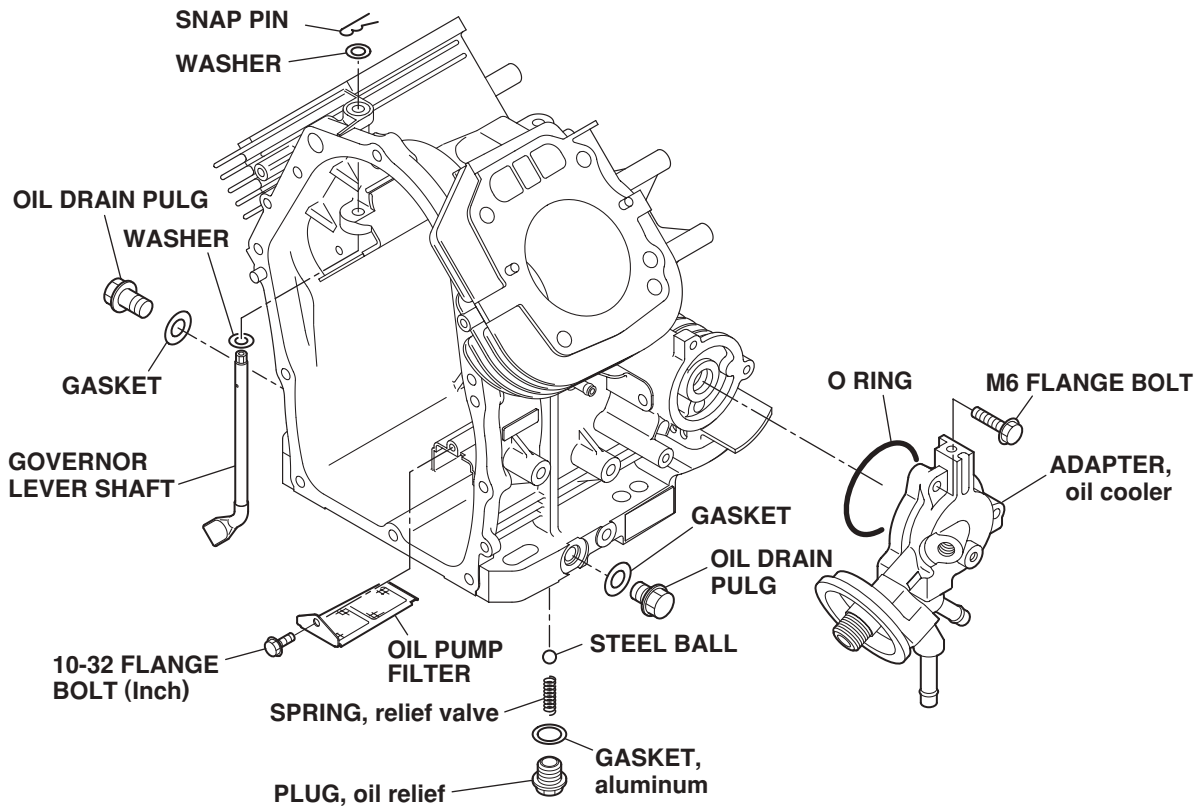

## B. CYLINDER HEAD, VALVES and ROCKER ARM

### NOTE ;

- \* Clean valves and wash cylinder head thoroughly.
- \* Remove carbon and gum deposits from the valves, seats, ports and guides.
- \* Inspect valves, valve seats and valve guides.
- \* Replace valves that are badly burned, pitted or warped.
- \* Valve guides should be replaced when valve stem clearance exceeds specifications.

(Refer to SERVICE DATA for clearance specifications. )

If exceeds, draw valve guides out and press new guides in.

After replacing valves and guides, lap valves in place until a uniform ring shows around the face of the valve.

- (1) Attach oil seal only onto intake valve guide.
- (2) Set retainer plate on exhaust valve side.
- (3) Apply oil to washer, valve spring and valve stem.  
Place cylinder head on flat table and install washer, valve spring, valve and spring retainer.
- (4) Install rocker arm.

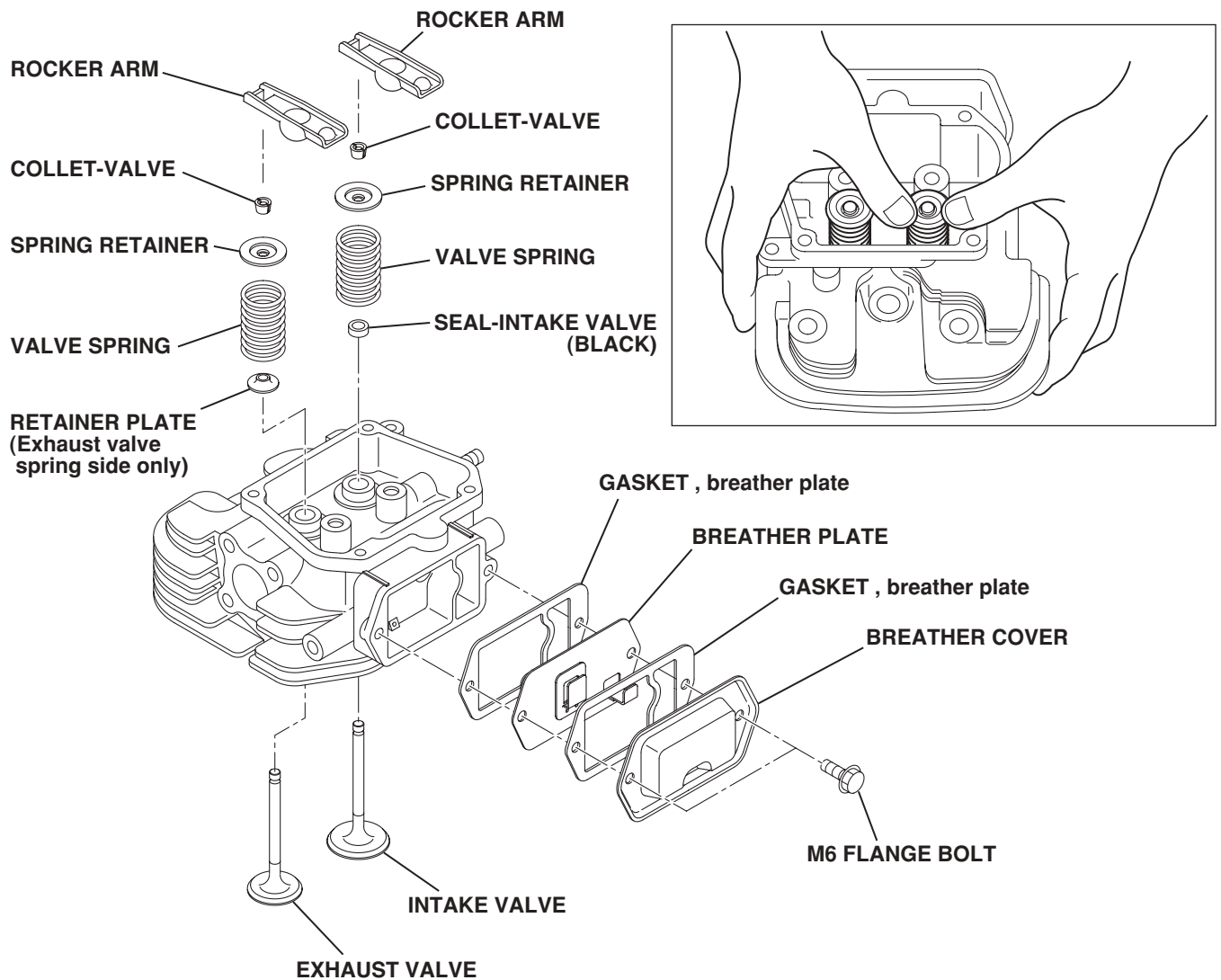

## C. PISTON RING and CONNECTING ROD

### (1) PISTON and PISTON RING

Install oil ring first, then second ring and top ring.  
Spread ring only far enough to slip over piston and into correct groove.  
Use care not to distort ring.

#### NOTE ;

- \* Top ring can be fit either way.
- \* Install second ring with punched mark beside the gap on the top side.
- \* As for oil ring, rails should be placed on and below the expander.

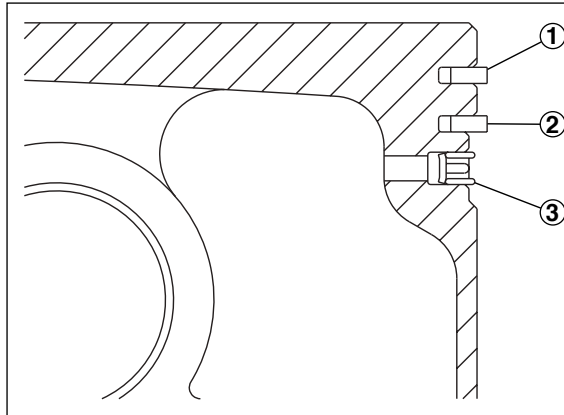

①	TOP RING	BARREL	
②	SECOND RING	TAPER	
③	OIL RING	COMBINATION RING	

### (2) PISTON and CONNECTING ROD

Apply enough oil to small end of connecting rod and piston pin, and fix connecting rod to piston with piston pin.  
Use clips on the both side of the piston pin to secure piston pin in position.

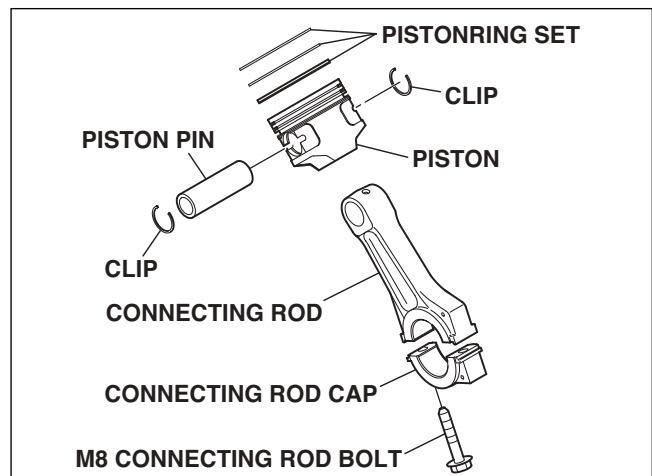

## D. MAIN BEARING COVER and GOVERNOR GEAR

- (1) Insert washer into governor gear shaft.
- (2) Insert governor gear along with sleeve into governor gear shaft.

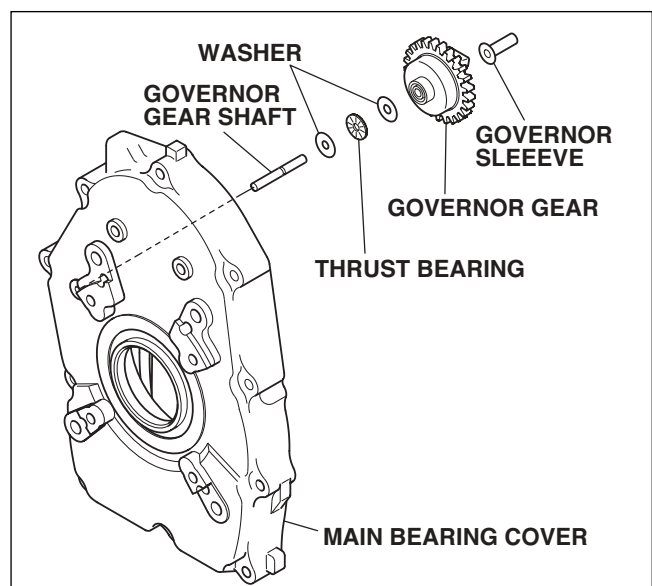

### 5-4-3 Re-assembly

#### 1) CRANKSHAFT

Install crankshaft onto crankcase.

**NOTE ;**

- \* Apply enough oil to bearing portion of crankcase.
- \* For smooth fitting of crankshaft, assemble oil pump related parts later.
- \* For easy installation, put crankcase on box or wood blocks.

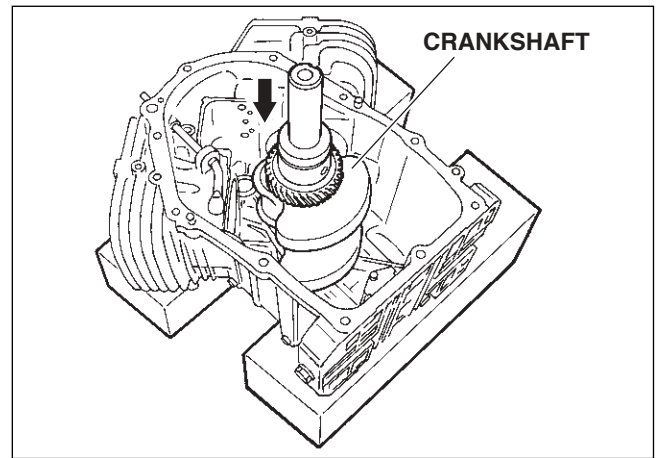

#### 2) PISTON and CONNECTING ROD

(1) Install piston and connecting rod assembly into cylinder by using a piston ring compressor to hold piston rings.

**NOTE ;**

- \* The "1" mark of the connecting rod for #1 cylinder and "2" mark for #2 cylinder should be faced to the PTO side when assembled.
- \* Apply enough oil to piston rings, connecting rod bearings (large end) and cylinder bore before assembly.
- \* Set gaps of piston rings as shown in the illustration.

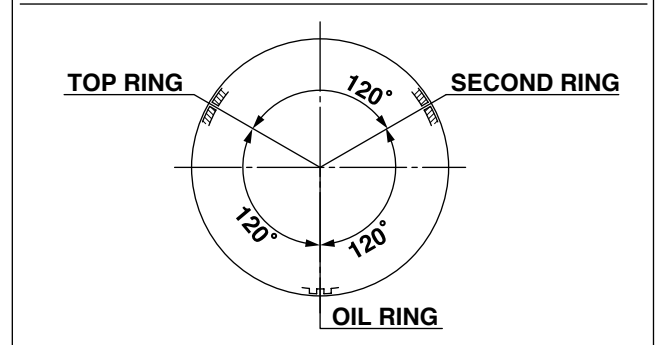
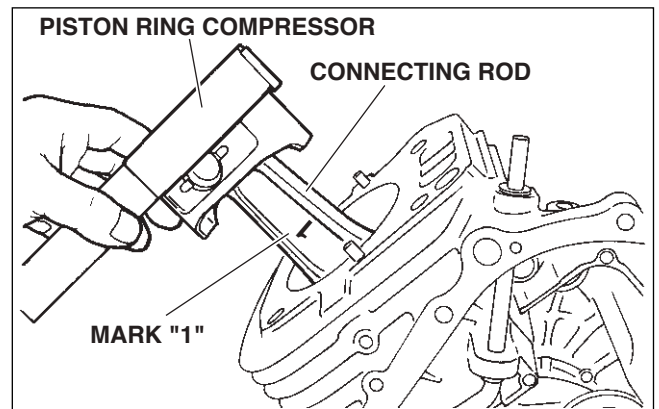

(2) Temporary fit key and flywheel and turn crankshaft to BTDC (bottom dead center). Lightly tap the top of piston until large end of the rod meet the pin portion of crankshaft.

(3) Set connecting rod cap to connecting rod with the alignment marks mated and the clinching portion clinched. Tighten bolts to the specified torque.

M8 Connecting rod bolt : 4 pcs.

Tightening torque
22.0 - 27.0 N•m (225 - 275 kgf•cm) (16.3 - 19.8 ft•lb.)

**NOTE ;**

- \* When depressing connecting rod, make sure not to damage another connecting rod.
- \* Check for free movement of piston and connecting rod by turning crankshaft slowly.

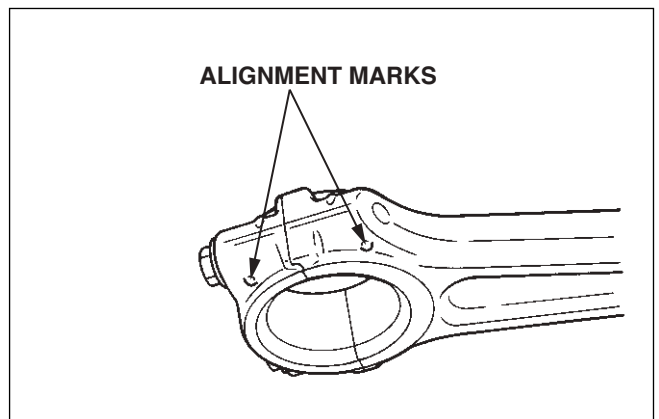

### 3) TAPPET and CAMSHAFT

- (1) Apply oil to tappets and install in their original position. Push in fully to avoid damage during camshaft installation.
- (2) Lubricate bearing surfaces of camshaft. Install camshaft into the crankcase with the timing mark on both crankshaft gear and camshaft aligned.

**CAUTION:**  
Incorrect alinement will cause malfunction of the engine.

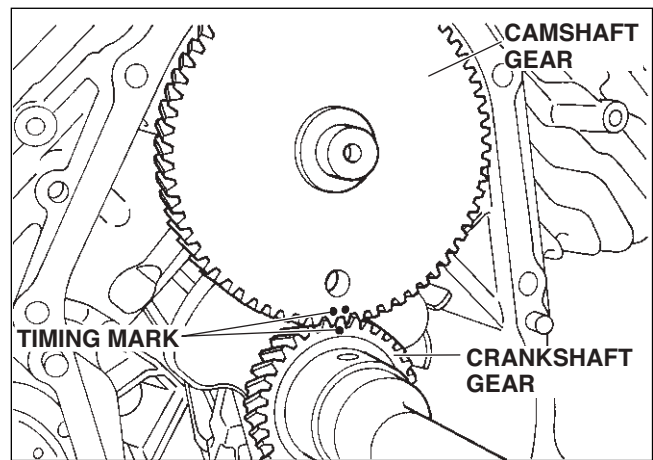

### 4) Adjust side clearance

Measure end play of crankshaft and camshaft. Adjust end play to "0" using the proper spacer.

$$\text{SPACER (mm)} = \text{"A"} + 0.48 - \text{"B"} \text{ (① - ②)}$$

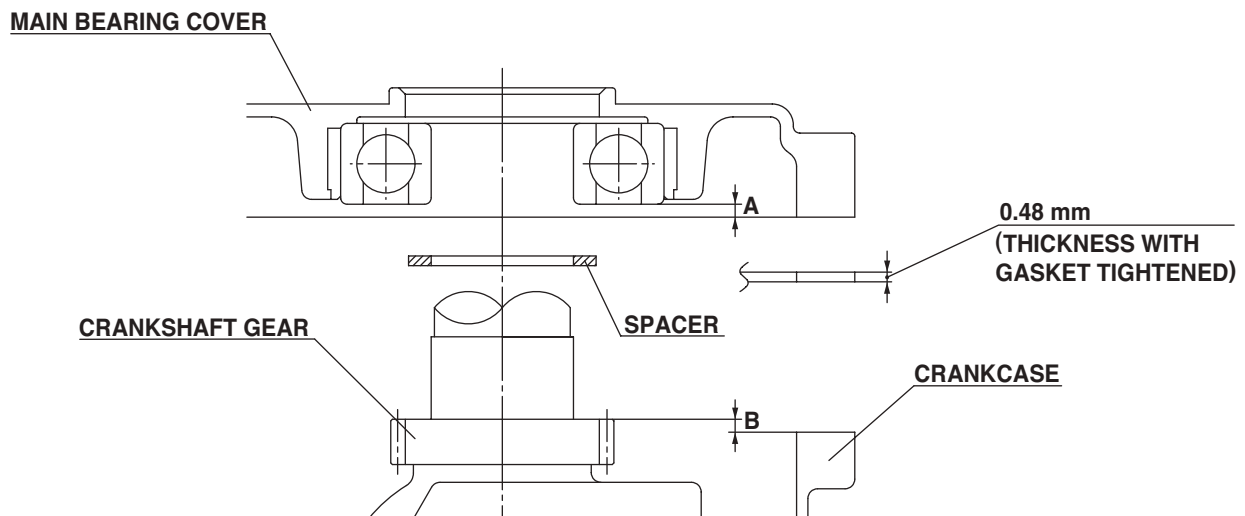
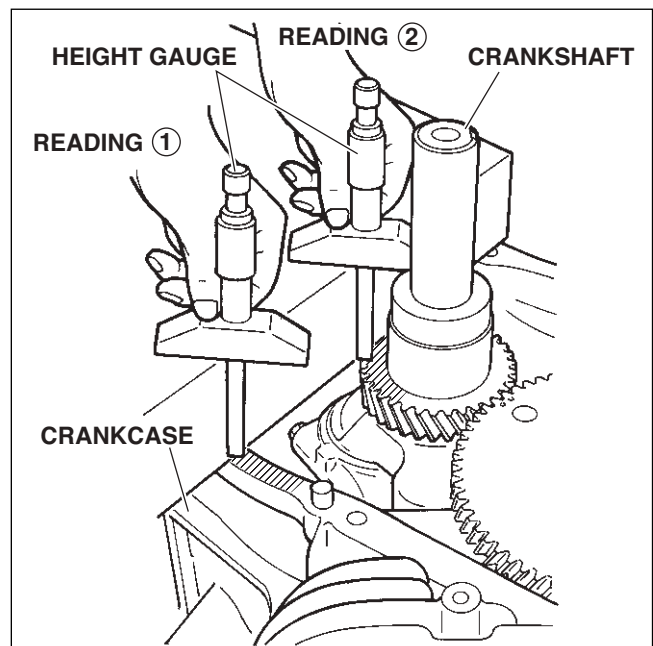



### 5) MAIN BEARING COVER

- (1) Put a oil seal guide onto PTO shaft portion to avoid damaging the main bearing cover oil seal.
- (2) Place gasket onto the mating surface of crankcase.
- (3) Lubricate oil seal lip portion and bearing surfaces, and install main bearing cover.

Tighten bolts evenly to the specified torque.

M8 x 45 Flange bolt : 10 pcs.

Tightening torque
22.5 - 27.5 N·m (230 - 280 kgf·cm) (16.5 - 20.2 ft·lb.)

**NOTE ;**

- \* Before installing main bearing cover, be sure to check the installation of governor lever shaft and oil pump filter in the crankcase in position.
- \* Tap cover with a soft hammer until tatching the crankcase mating surface, engaging with governor gear and camshaft gear properly.
- \* Rotate crankshaft slowly to check for smooth operation and side clearance.

### 6) OIL PUMP and COVER

- (1) Apply oil to inner and outer rotors of oil pump and attach them in position.
- (2) Set O-ring in position.
- (3) Install oil pump cover with the allow marking upwards.

M6 x 18 Flange bolt : 4 pcs.

Tightening torque
6.8 - 8.8 N·m (70 - 90 kgf·cm) (5.1 - 6.5 ft·lb.)

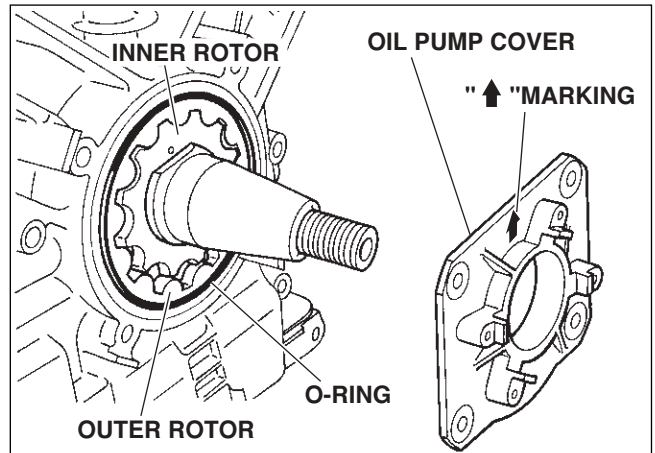

### 7) CYLINDER HEAD

- (1) Set dowel pins in the holes on the cylinder head surface.
- (2) Attach head gaskets in position onto #1 and #2 cylinder head surfaces.
- (3) Install #1 and #2 cylinder heads. Tighten bolts evenly in steps to the specified torque.

M10 x 65 Flange bolt : 4 pcs.

Tightening torque
41.0 - 49.0 N·m (400 - 500 kgf·cm) (30.2 - 36.1 ft·lb.)

**NOTE :**  
Be sure to check dowel pin, and replace with new one if damaged.

Tighten the cylinder head bolts in diagonal order.

Cylinder head bolts	Tightning Torque		
		<b>1st step</b> 25 N·m (255 kgf·cm) (18.4 ft·lb.)	<b>2nd step</b> 35 N·m (357 kgf·cm) (25.8 ft·lb.)



## 8) PUSH RODS

Rotate crankshaft to the position in the no lifted condition of tappet.  
Be sure to loose the rocker arm adjust screw.

- (1) Insert push rods into the concave portion of tappet and set the other end to the concave portion of rocker arm adjust screw with valve spring depressed.
- (2) Temporally tighten adjust screw.

## 9) VALVE CLEARANCE ADJUSTMENT

**NOTE ;**  
**Temporally fit the flywheel in position for easy operation.**

- (1) Rotate crankshaft clockwise to the TDC (top dead center) of compression stroke by matching the mark "T" of flywheel with the mark "1" of #1 cylinder head.
- (2) Loosen lock nut on rocker arm and turn adjusting screw to adjust the clearance between rocker arm and valve stem end, and then tighten lock nut to the specified torque.

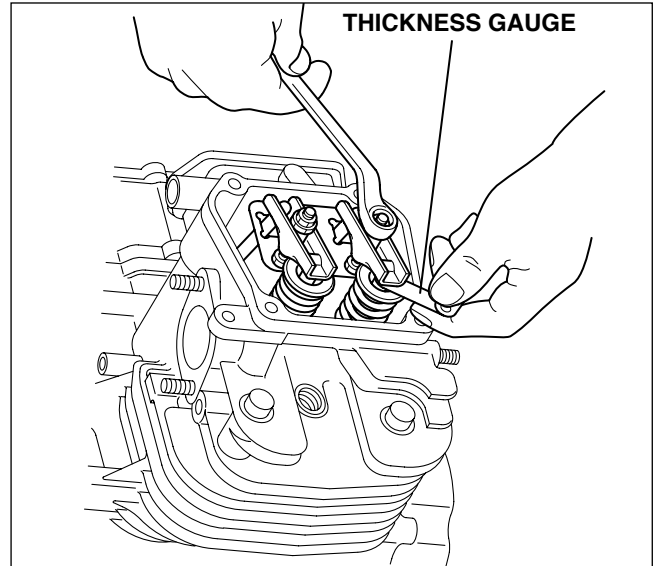

<b>Valve Clearance (Cold condition)</b>
---

0.07 - 0.13 mm (0.003 - 0.005 in.)
------------------------------------

Lock nut

<b>Tightening torque</b>
--------------------------

6.8 - 8.8 N·m (70 - 90 kgf·cm) (5.0 - 6.5 ft·lb.)
---

Pivot bolt

<b>Tightening torque</b>
--------------------------

16.6 - 18.6 N·m (170 - 190 kgf·cm) (12.3 - 13.7 ft·lb.)
---

- (3) Adjust valve clearance of #2 cylinder side in the same manner.
- (4) Rotate crankshaft several times and be sure to check valve clearance again. Adjust valve clearance if necessary.

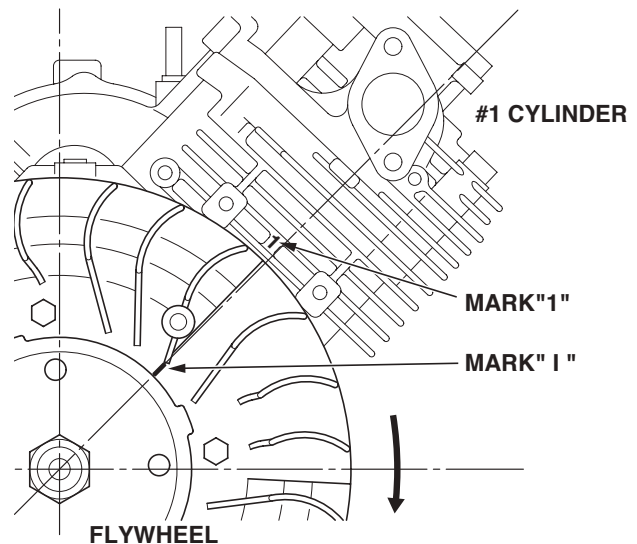

## 10) ROCKER COVER

Install rocker cover with new gasket.

M6 x 28 Flange bolt : 8 pcs.

<b>Tightening torque</b>
--------------------------

6.8 - 8.8 N·m (70 - 90 kgf·cm) (5.0 - 6.5 ft·lb.)
---

### 11) BREATHER PIPE and COVER

Attach breather plate (breather valve) and breather cover to crankcase using proper gaskets.  
Put breather plate in such position as its reed valve opens outside.

M6 x 14 Flange bolt : 2 pcs.

Tightening torque
2.9 - 4.9 N·m (30 - 50 kgf·cm) (2.2 - 3.6 ft·lb.)

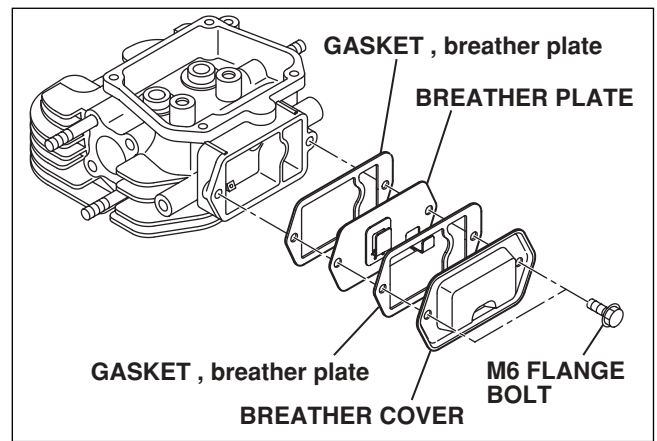

#### NOTE ;

- \* Never tighten the bolts over the specified torque, or gasket is damaged and cut.
- \* Replace gaskets with new ones if they are torn or damaged.

### 12) SPARK PLUG

Install spark plug to each cylinder head.  
Check the carbon and heat damage around electrode and clean or replace with new one as necessary.

Spark plug : NGK - BPR4EY

Tightening torque	
New plug	Current plug
11.7 - 14.7 N·m (120 - 150 kgf·cm) (8.6 - 10.8 ft·lb.)	22.1 - 26.9 N·m (225 - 275 kgf·cm) (16.3 - 19.8 ft·lb.)

### 13) CHARGE COIL

Install charge coil with the wiring located at 2-o'clock position.

M5 x 20 bolt & washer : 4 pcs.(15A coil)

M5 x 25 bolt & washer : 4 pcs.(30A coil)

Tightening torque
2.9 - 3.9 N·m (30 - 40 kgf·cm) (2.2 - 2.9 ft·lb.)

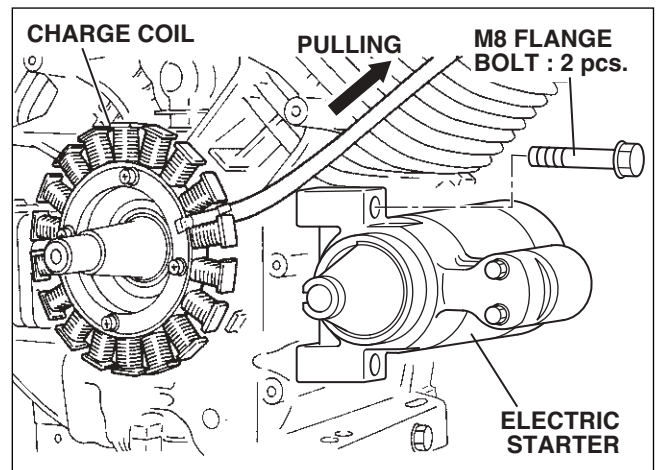

### 14) STARTER MOTOR

Install starter motor.  
M8 x 65 Flange bolt : 2 pcs.

Tightening torque
16.6 - 18.6 N·m (170 - 190 kgf·cm) (12.3 - 13.7 ft·lb.)

### 15) CYLINDER BAFFLE

Attach cylinder baffle #1, #2 and #3.  
Attach cylinder baffle #4 with the charge coil harness retracted in the dent portion.

M6 x 12 Flange bolt

## 16) INTAKE MANIFOLD

- (1) Set gasket (stainless steel) onto both #1 and #2 cylinder head.
- (2) Install intake manifold.

M8 flange nut : 4 pcs.

Tightening torque
16.6 - 18.6 N·m (170 - 190 kgf·cm) (12.3 - 13.7 ft·lb.)

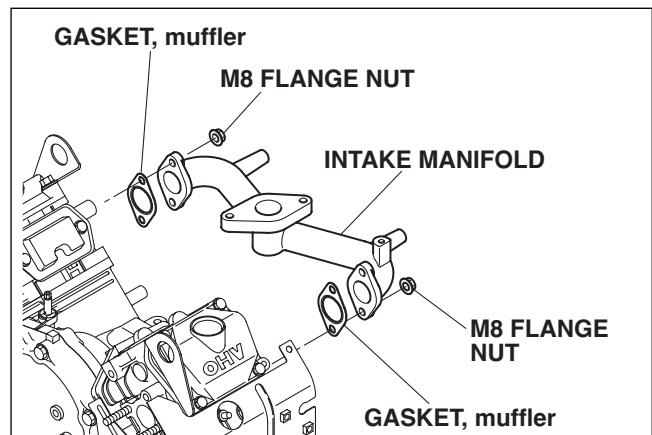

## 17) OIL COOLER (EH72 only)

- (1) Attach bracket.
- (2) Assemble oil cooler onto bracket.

M6 x 12 Flange bolt : 4 pcs.

Tightening torque
6.8 - 8.8 N·m (70 - 90 kgf·cm) (5.0 - 6.5 ft·lb.)

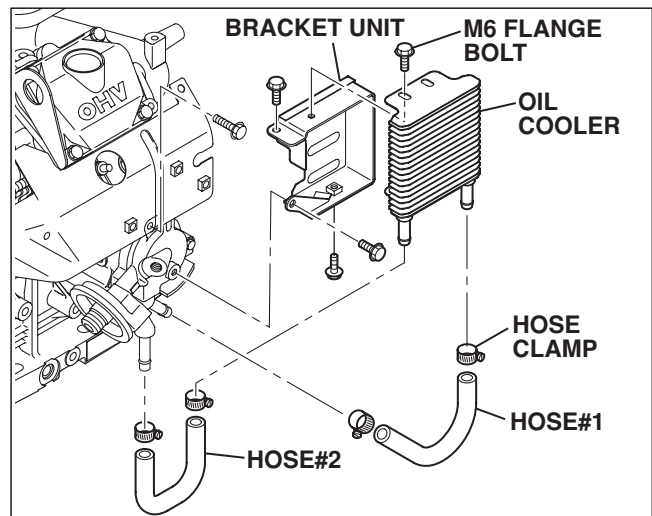

## 18) REGULATOR

Install regulator onto cylinder baffle #1.  
Install regulator onto cylinder baffle #1 with the terminal of earth wire (white) commonly fixed on the right-hand side.  
Connect charge coil wire connector to regulator.  
Connect wire (green) to magnetic switch.

M6 x 18 Flange bolt : 2 pcs.

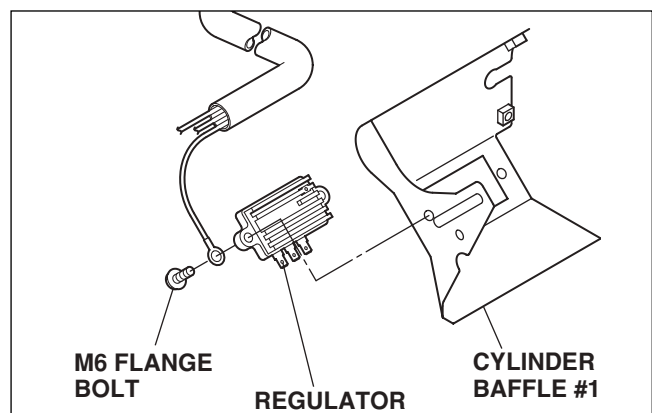

## 19) FLYWHEEL

- (1) Put woodruff key in the keyway of crankshaft.
- (2) Wipe off oil and grease thoroughly from tapered portion of crankshaft and flywheel center hole.
- (3) Install flywheel to crankshaft and tighten flywheel nut with washer.

M18 flange nut : 1 pc.

Tightening torque
100 - 120 N·m (1020 - 1220 kgf·cm) (73.8 - 88.5 ft·lb.)

## 20) IGNITION COIL and WIRE CP

Temporarily fit ignition coil to crankcase.  
Adjust air gap between ignition coil and flywheel  
using a thickness gauge and tighten bolts.

Ignition coil air gap
0.3 - 0.5 mm (0.012 - 0.020 in.)

M6 x 30 bolt & washer : 4 pcs.

Tightening torque
6.8 - 8.8 N·m (70 - 90 kgf·cm) (5.1 - 6.5 ft·lb.)

Connect wiring from key switch to the primary terminal of ignition coil.

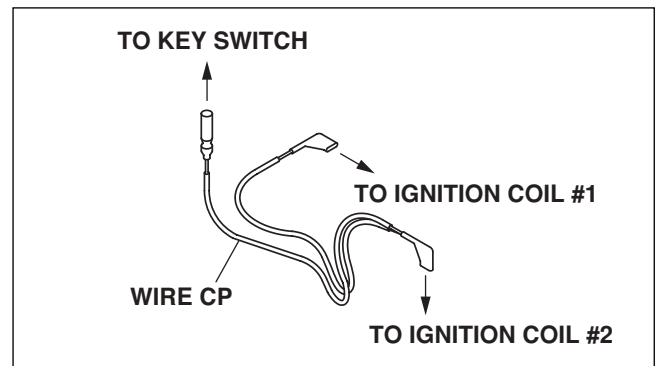
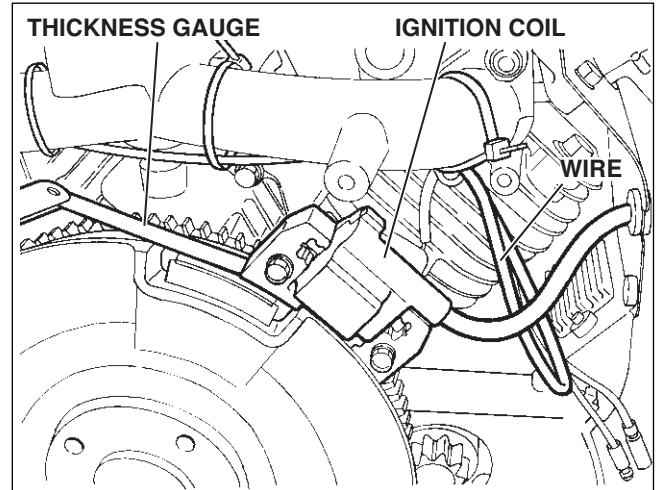

## 21) COOLING FAN

Attach cooling fan onto flywheel.  
M6 x 16 bolt & washer : 4 pcs.

Tightening torque
6.8 - 8.8 N·m (70 - 90 kgf·cm) (5.1 - 6.5 ft·lb.)

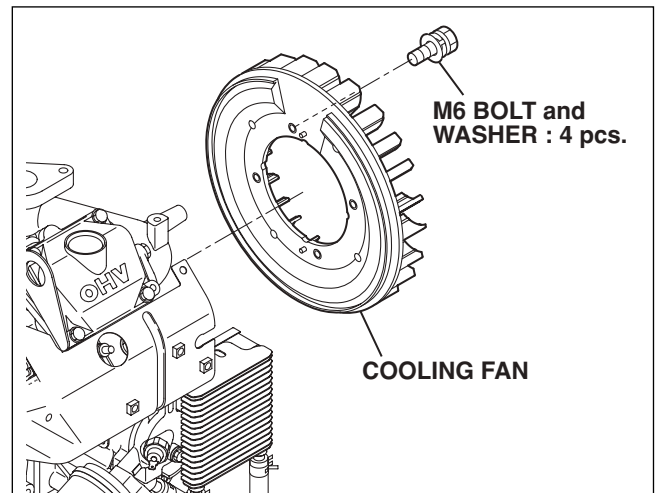

## 22) CARBURETOR

Set gasket onto intake manifold and install carburetor.

M8 x 80 Flange bolt : 2 pcs.

Tightening Torque
16.6 - 18.6 N·m (170 - 190 kgf·cm) (12.3 - 13.7 ft·lb.)

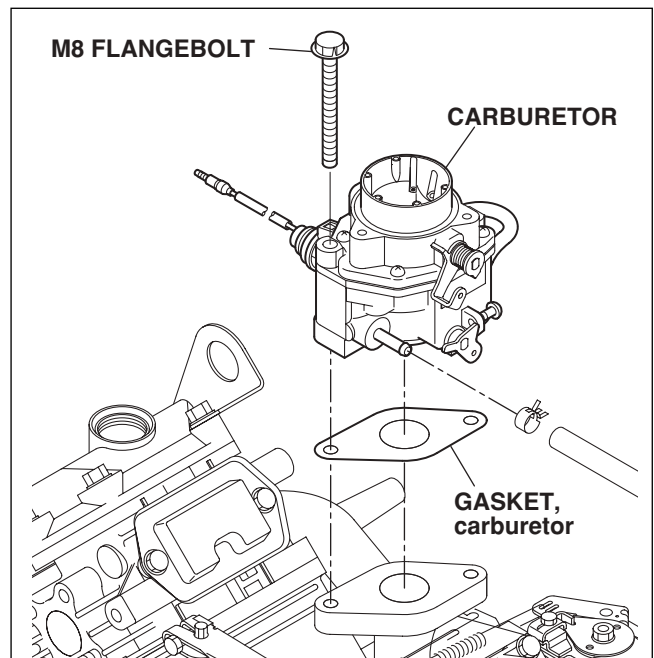

## 23) CHOKE CONTROL

Attach chock control link between carburetor chock lever and chock control lever.

Attach governor spring between governor lever and speed control lever.

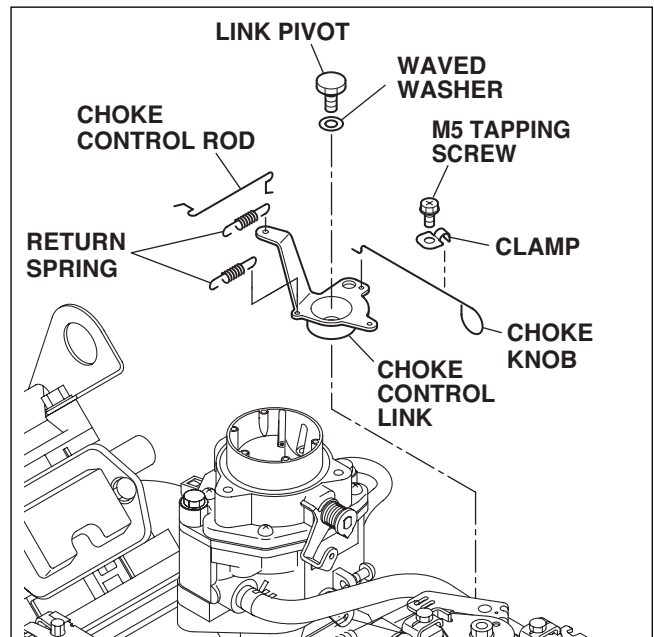

## 24) GOVERNOR LEVER

Attach governor rod and rod spring between governor lever and carburetor throttle lever, and insert the governor lever to governor lever shaft. Tighten locking bolt temporarily.

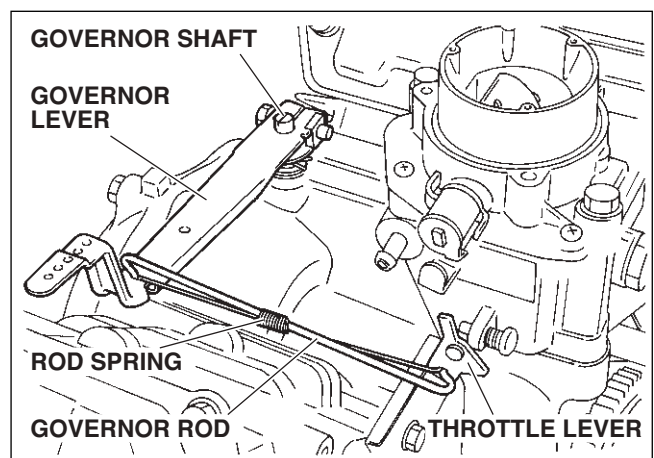

## 25) SPEED CONTROL LEVER

- (1) Install speed control bracket onto intake manifold.
- (2) Attach return spring, spacer, friction washer, wing nut, etc. to speed control lever as shown in the illustration.
- (3) Connect governor spring to governor lever and speed control lever.
- (4) Fit chock control link between carburetor chock lever and chock control lever.

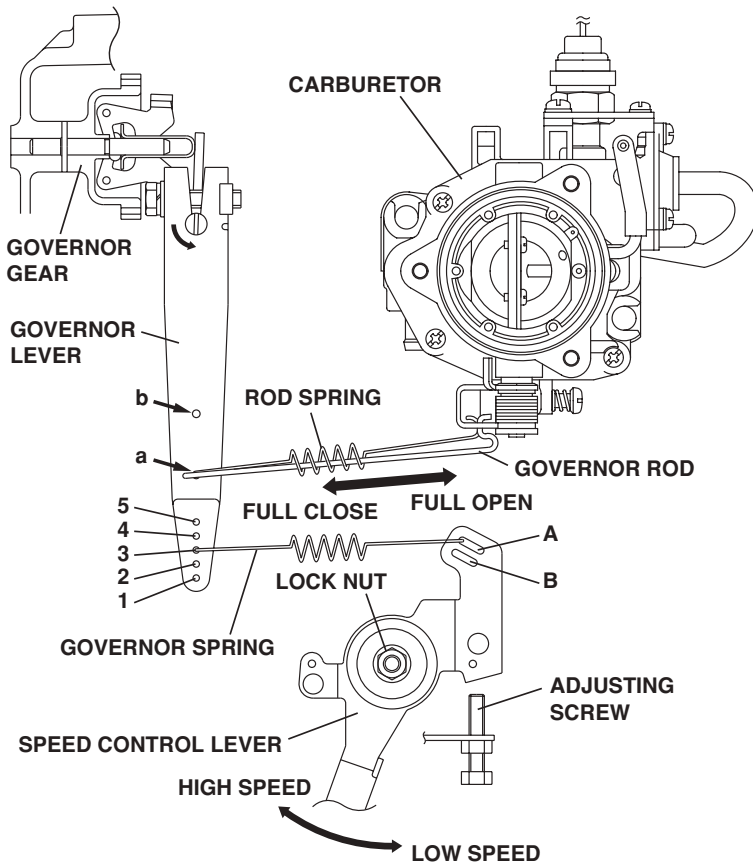
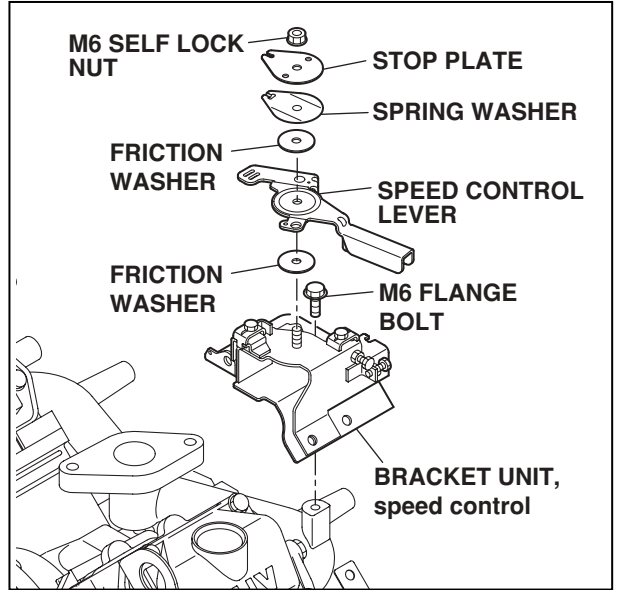

Fitting location of governor rod and governor spring

	50Hz	60Hz
EH63	A-3(b)	A-2(b)
EH64	A-3(b)	A-2(b)
EH65	A-3(a)	A-2(a)
EH72	A-5(a)	A-4(a)

## 26) ADJUST GOVERNOR SYSTEM

- Governor system is centrifugal flyweight type.  
Governor weight is installed into governor gear driven by crankshaft.  
Governor weight movement is transferred to carburetor throttle lever via governor shaft and lever.
  - Engine speed is maintained at the constant speed by carburetor throttle valve opening and closing operation in accordance with load condition of engine.
- (1) Push speed control lever all the way to the high speed position and fix it by tightening nut.
  - (2) Check that governor lever is pulled by governor spring and carburetor throttle valve is fully open.
  - (3) Turn governor shaft counterclockwise all the way and tighten lock bolt to secure the lever on the shaft.

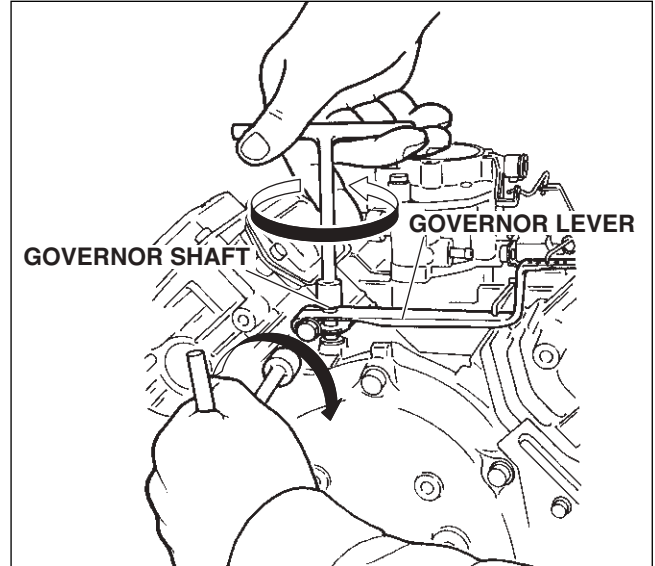

## 27) BLOWER HOUSING

Attach blower housing to crankcase with control box commonly fixed.  
Connect fuel pipes onto blower housing.

BLOWER HOUSING(Front)  
M6 x 14 Flange bolt : 4 pcs.

Tightening torque
3.9 - 5.9 N·m (40 - 60 kgf·cm) (2.9 - 4.3 ft·lb.)

BLOWER HOUSING(Side)  
M6 x 18 Flange bolt : 2 pcs.  
M6 x 14 Flange bolt : 2 pcs.

Tightening torque
2.9 - 4.9 N·m (30 - 50 kgf·cm) (2.2 - 3.6 ft·lb.)



## 28) FUEL PUMP and FUEL PIPE

- (1) Install fuel pump bracket onto #2 cylinder baffle.

FUEL PUMP BRACKET  
M6 x 12 Flange bolt : 2 pcs.

Tightening torque
6.8 - 8.8 N·m (70 - 90 kgf·cm) (5.0 - 6.5 ft·lb.)

- (2) Install fuel pump onto fuel pump bracket.

FUEL PUMP  
M6 x 12 Flange bolt : 2 pcs.

Tightening torque
4.5 - 5.5 N·m (45 - 56 kgf·cm) (3.3 - 4.1 ft·lb.)

- (3) Connect fuel pipe between carburetor and fuel pump.

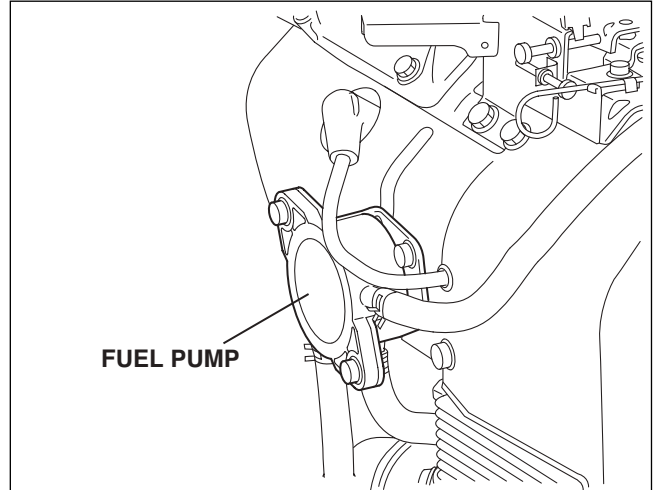

## 29) AIR CLEANER and BREATHER PIPE

- (1) Connect breather pipe to air cleaner base.  
(2) Fit air cleaner base onto carburetor.

M6 x 12 Flange bolt : 3 pcs.

Tightening torque
6.8 - 8.8 N·m (70 - 90 kgf·cm) (5.0 - 6.5 ft·lb.)

- (3) Connect breather pipe to #1 cylinder head.  
(4) Set air cleaner element along with urethane foam onto base.  
(5) Install air cleaner cover with knob.

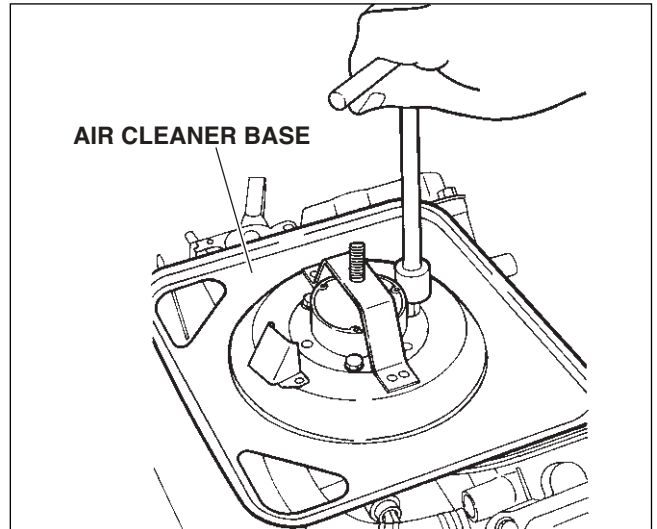



### 30) OIL PRESSURE SWITCH

- Install oil pressure switch onto crankcase. [EH63, 64, 65]
- Install oil pressure switch onto adapter(Oil cooler). [EH72]

Tightening torque
5.9 - 9.8 N·m (60 - 100 kgf·cm) (4.3 - 7.2 ft·lb.)

**NOTE ;**  
**Not to tighten excessively.**

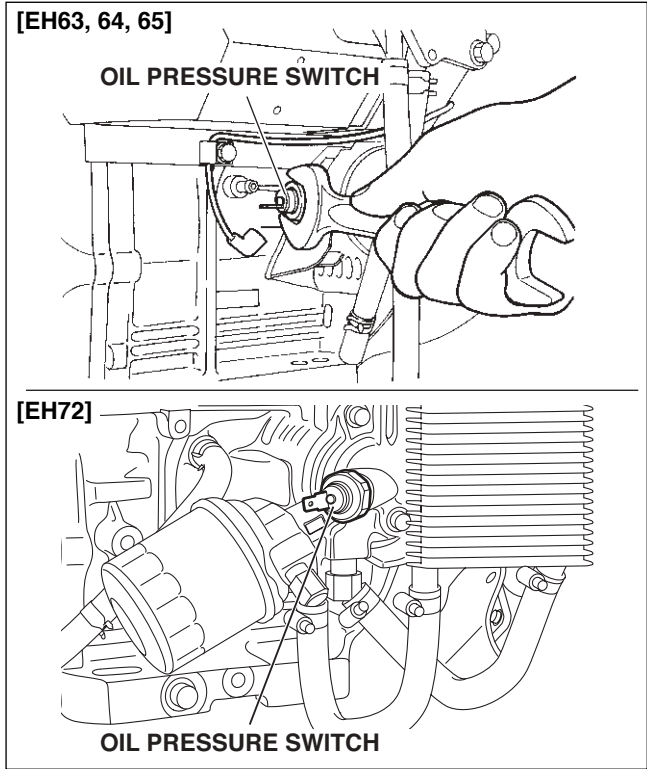

### 31) OIL FILTER

Apply oil to O-ring and install oil filter by tightening about 3/4 turns after attaching crankcase surface.

Tightening torque
9.9 - 14.7 N·m (100 - 150 kgf·cm) (16.3 - 19.8 ft·lb.)

**NOTE ;**  
**Start engine after assembling,**  
**and check for no oil leakage**  
**from oil filter.**

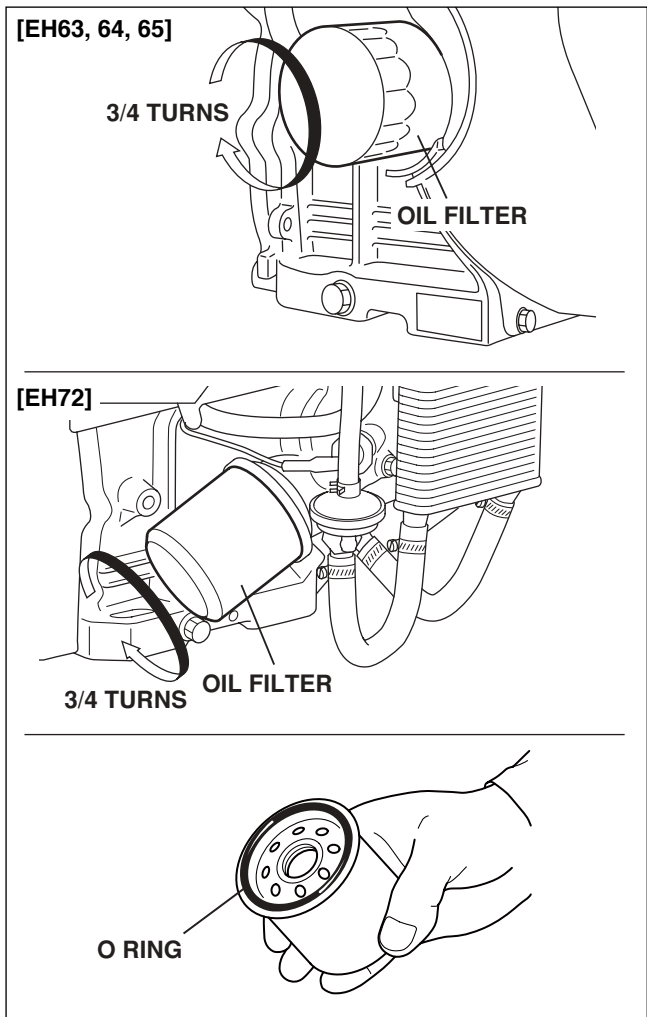

### 32) FUEL PUMP PLUSE PIPE

Connect fuel pipe between fuel pump and crankcase nipple.

### 33) MUFFLER

(1) Install Muffler bracket onto Cylinder head.

M8 x 20 bolt & washer : 2 pcs.

Tightening torque
16.6 - 18.6 N·m (170 - 190 kgf·cm) (12.3 - 13.7 ft·lb.)

(2) Install Muffler onto Muffler bracket and Cylinder head.

M8 SUS flange nut : 4 pcs.

Tightening torque
16.6 - 18.6 N·m (170 - 190 kgf·cm) (12.3 - 13.7 ft·lb.)

(3) Install Muffler cover onto Muffler.

M6 Flange bolt : 6 pcs.

Tightening torque
6.8 - 8.8 N·m (70 - 90 kgf·cm) (5.0 - 6.5 ft·lb.)

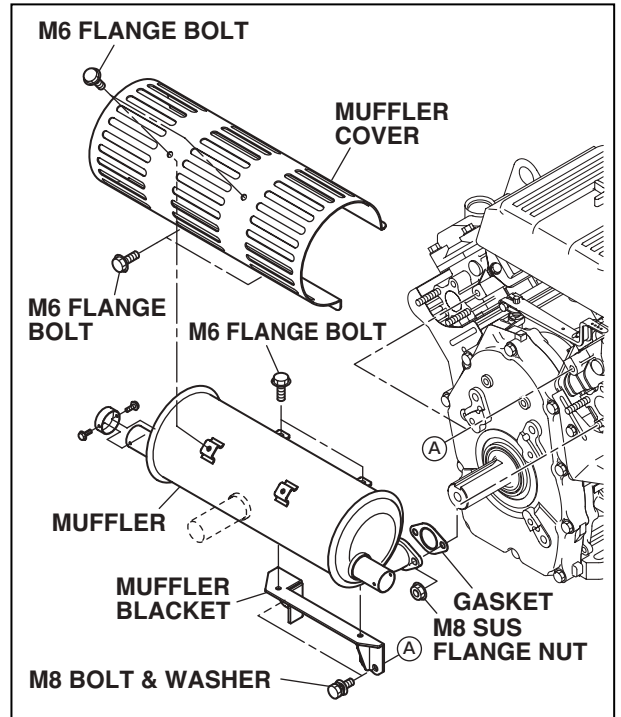

### 34) FINAL CHECK

Be sure to check loosen bolts and nuts, and also electric wiring connections.

### 35) ENGINE OIL

Refill engine oil and start the engine.  
 Engine oil will be lubricated oil passages and oil filter. Check the engine oil level and refill again to the upper level of oil level gauge.

<b>Oil Capacity</b>
1.55 liter (0.41 U.S. gal.)

**NOTE ;**  
 \* Check the oil level with the oil gauge inserted.  
 \* Use "SE" (API classification) or higher grade engine oil.

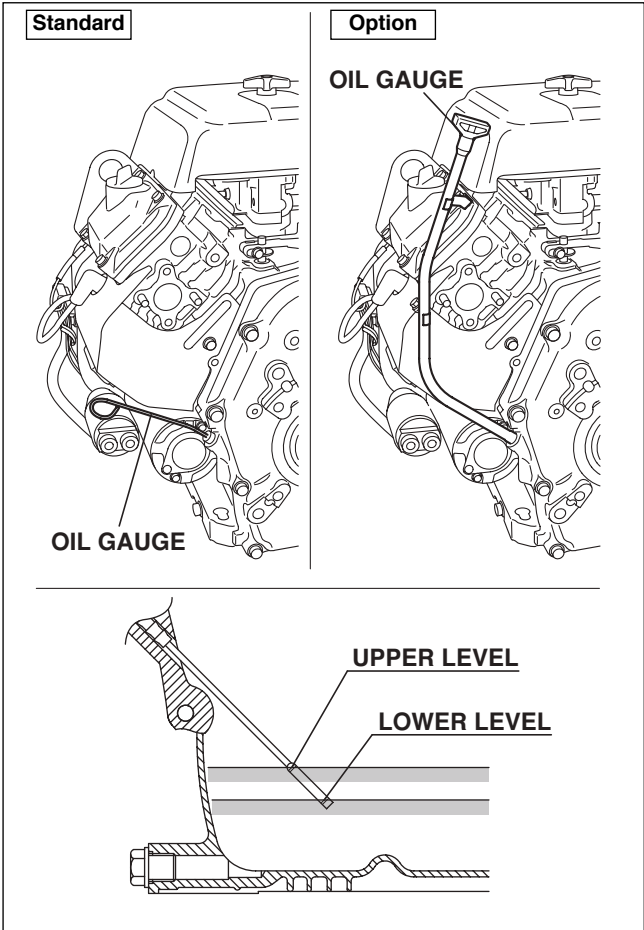
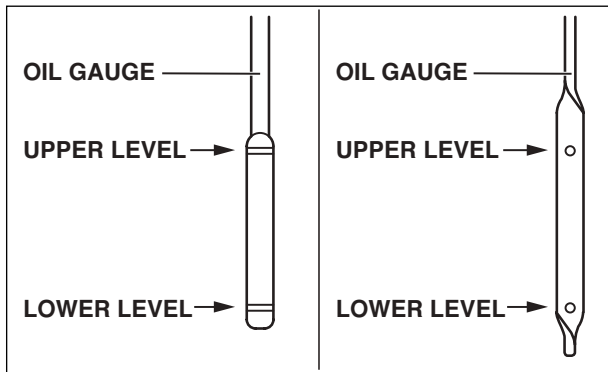

### 5-5 BREAK-IN OPERATION

An engine that has been completely overhauled by being fitted with a new piston, rings, valves and connecting rod should be thoroughly RUN-IN before being put back into service. Good bearing surfaces and running clearances between the various parts can only be established by operating the engine under reduced speed and loads for a short period of time.

While the engine is being tested, check for oil leaks.

Make final carburetor adjustment and regulate the engine operating speed.

STEP	EH63	EH64	EH65	EH72	Engine speed(rpm)	Time
1	No Load				2500	10
2					3000	10
3					3600	10
4	5.4kW (7.3HP)	5.9kW (7.3HP)	6.3kW (8.5HP)	6.7kW (9.0HP)	3600	30
5	10.8kW (14.5HP)	11.9kW (14.5HP)	12.7kW (17.0HP)	13.4kW (18.0HP)	3600	30

# 6. LUBRICATION SYSTEM

## OPERATION AND FUNCTION

- \* Full lubrication system is adopted, in combination with large-size trochoid oil pump and cartridge type oil filter.
- \* The large-size trochoid type oil pump is driven directly by crankshaft, and delivers pressurized engine oil to the journal and pin portions of crankshaft, camshaft etc.
- \* The engine oil in the oil pan is fed through the oil pump filter into oil pump and the engine oil pressure is adjusted by the relief valve after discharging from oil pump. Through the oil cooler and cartridge type oil filter, the engine oil is provided onto the rotating portions such as journal and pin portion of crankshaft and camshaft. The splashed engine oil is provided to the cylinder, piston, cylinder head valve system.
- \* The by-pass valve is incorporated into the cartridge type oil filter. In case that the oil filter element is clogged, the engine oil is fed through the by-pass valve into the crankcase oil passage.

[EH63, 64, 65]

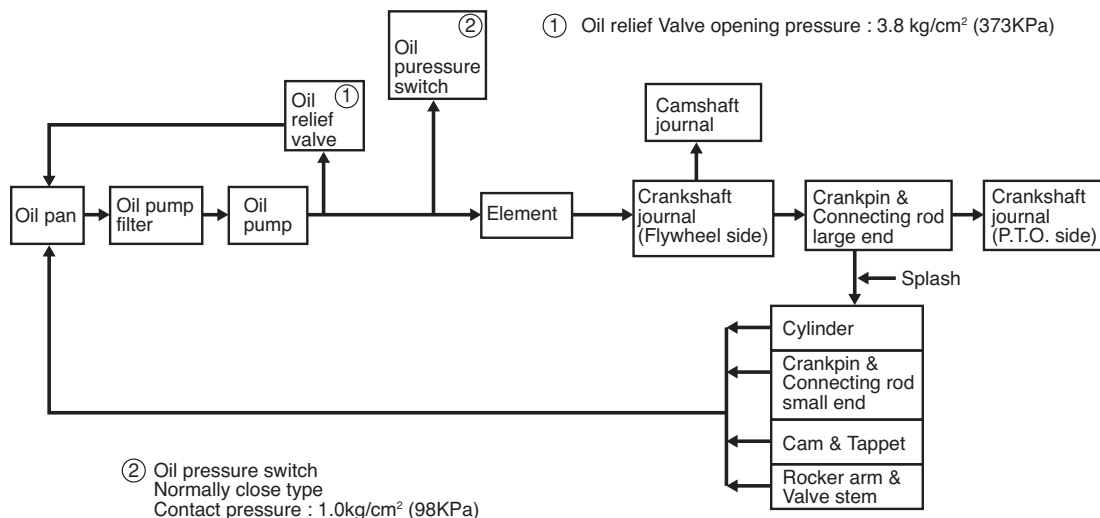
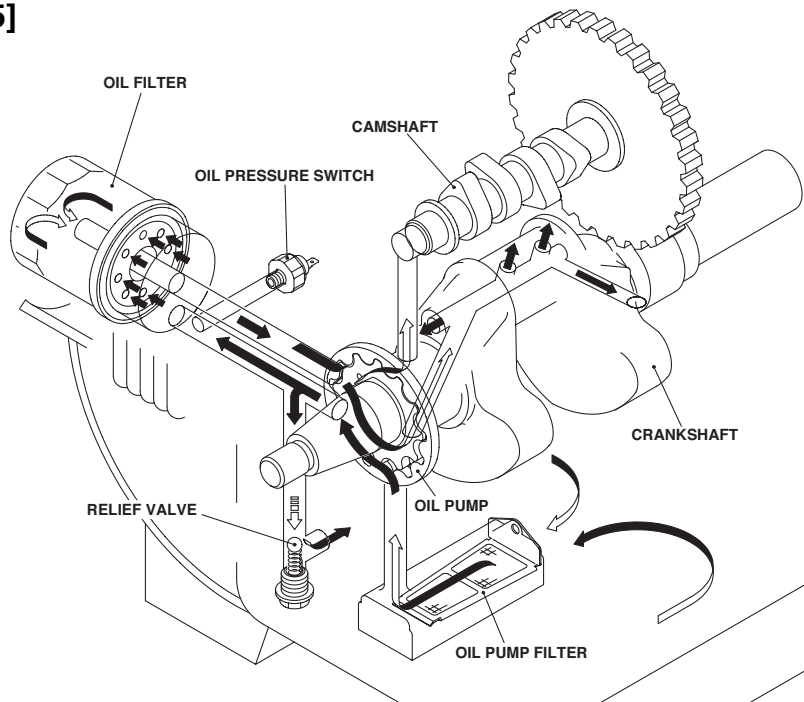

[EH72]

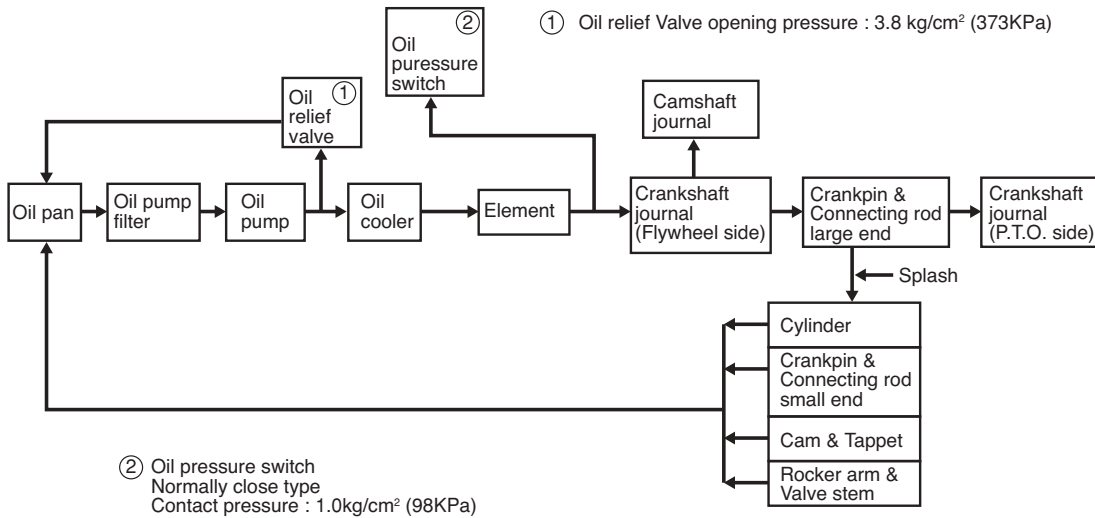
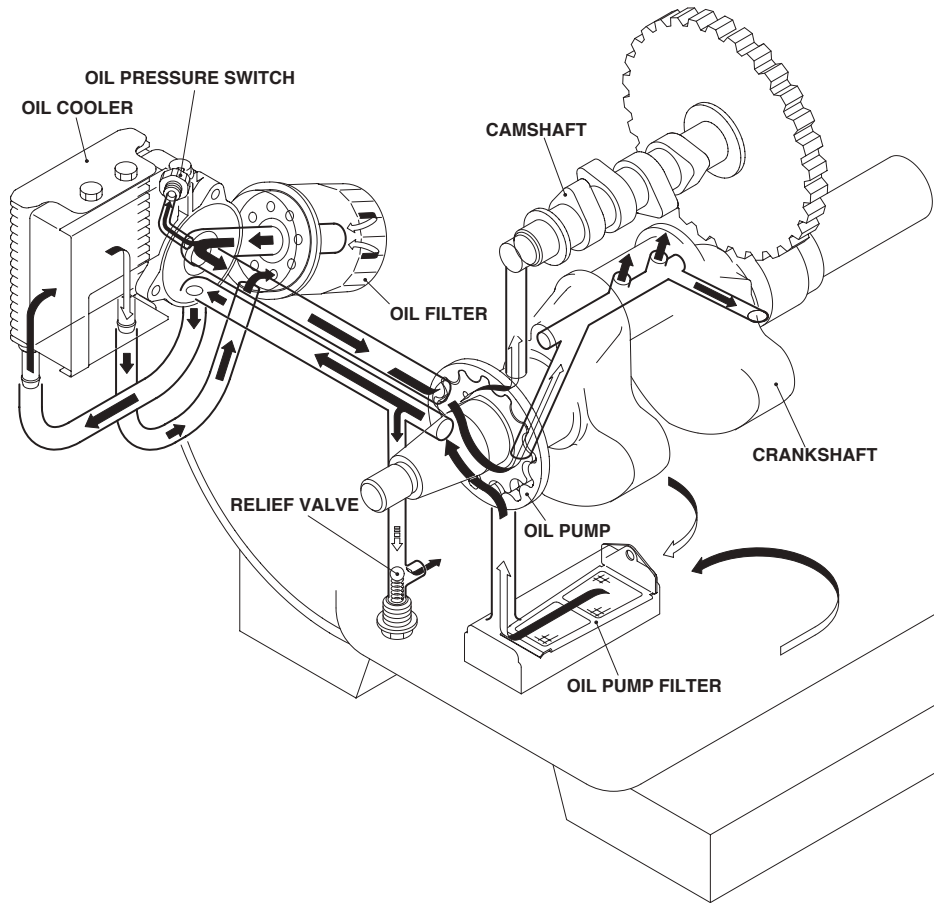

## ENGINE OIL

Using engine oil of the correct grade and viscosity greatly lengthens engine life and improves performance. Too much or too little oil can also result in serious problems, including engine seizure.

### • CLASSIFICATION BY OIL GRADE API (American Petroleum Institute)

Classification	SA	SB	SC	SD	SE	SF	SG	SH	SJ
----------------	----	----	----	----	----	----	----	----	----



Grades suited for Robin Engine: SE or higher (SG,SH or SJ in recommended)

### • CLASSIFICATION BY OIL VISCOSITY SAE (Society of Automotive Engineers)

Single grade	5W	10W	20W	#20	#30	#40	
	10W-30		10W-40				
Multigrade							
Ambient temperature	-20	-10	0	10	20	30	40°C
	-4	14	32	50	68	86	104°F

Be sure to use automobile engine oil of the viscosity shown in the table above, depending on environmental air temperature.

When the air temperature falls below  $-20^{\circ}\text{C}$  or rises above  $40^{\circ}\text{C}$ , be sure to choose engine oil of appropriate viscosity and grade, according to the prevailing conditions.

※ Care must be taken when using multi-grade engine oil, because the oil consumption rate tends to increase when the air temperature is high.

### • ADDING AND CHANGING ENGINE OIL

- Engine oil inspection and filling up . . . . . Every time you use the engine  
(add engine oil up to the designated maximum level)
- Engine oil change . . . . . First time After 20 hours' use  
Thereafter Every 100 hours' use

# 7. FUEL SYSTEM

## 7-1 FUEL PUMP

### ● Fuel suction process

The inside of crankcase becomes vacuum condition in accordance with the piston moving upwards to the top dead center.

The vacuum pressure, which is introduced via hose into the pulse chamber of fuel pump, pulls the diaphragm, and then the inside of pump chamber becomes vacuum condition.

As the results, the suction valve is opened and fuel goes into pump chamber from suction chamber.

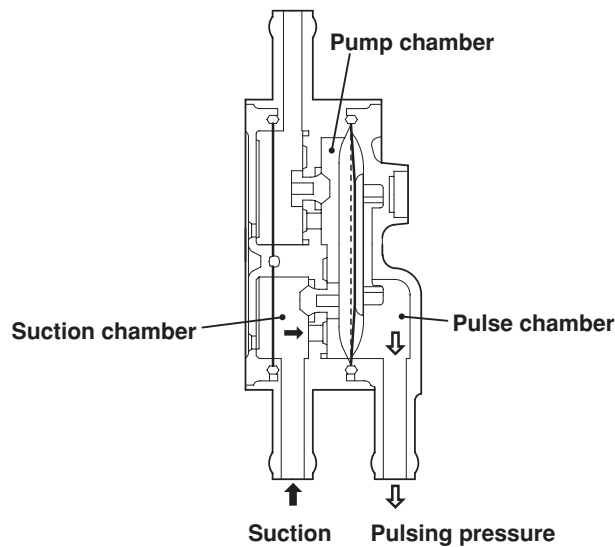

### ● Fuel discharge process

The vacuum pressure of crankcase inside is decreased in accordance with the piston moving downwards to the bottom dead center.

The vacuum pressure of the pulse chamber is also decreased and the diaphragm moved back by means of the return spring force.

The fuel in the pump chamber is pressed by the diaphragm, and delivered to the discharge chamber through the discharge valve.

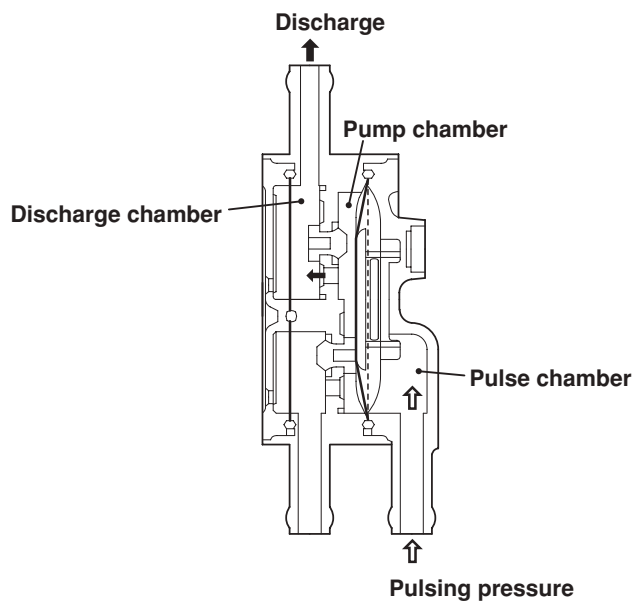

## 7-2. CARBURETOR

### OPERATION AND FUNCTION

[EH63, 64, 65]

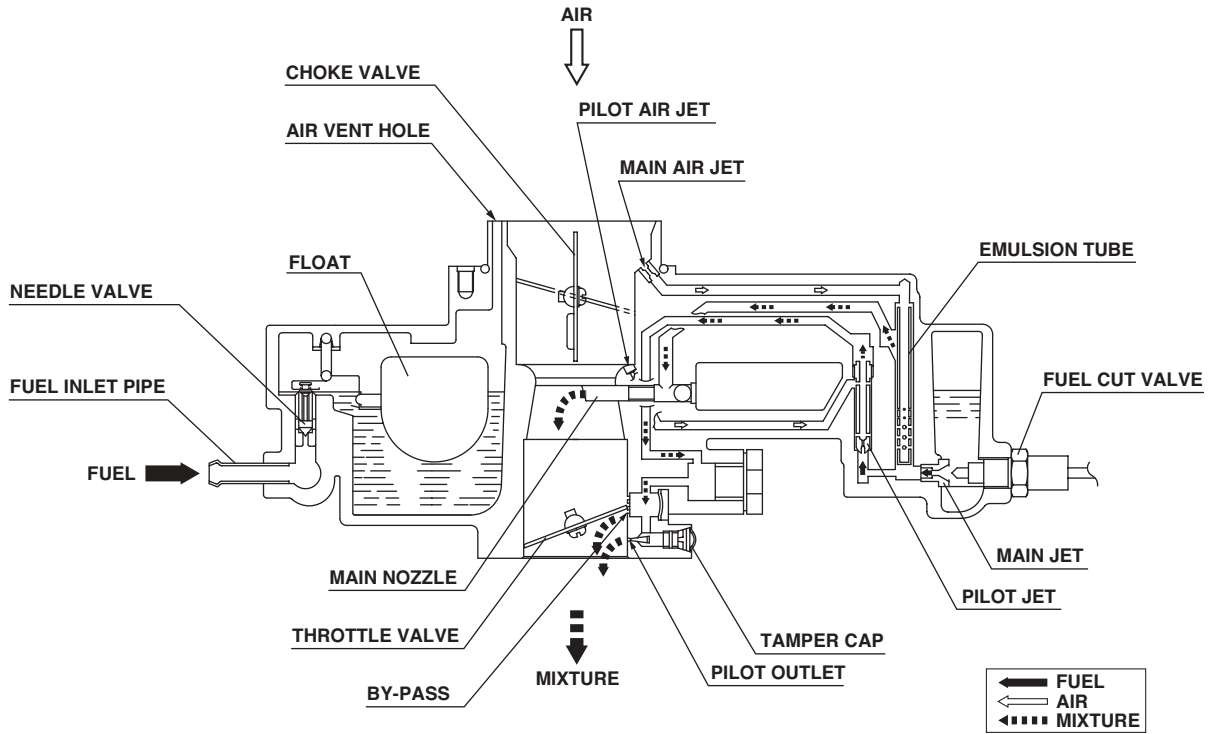

[EH72]

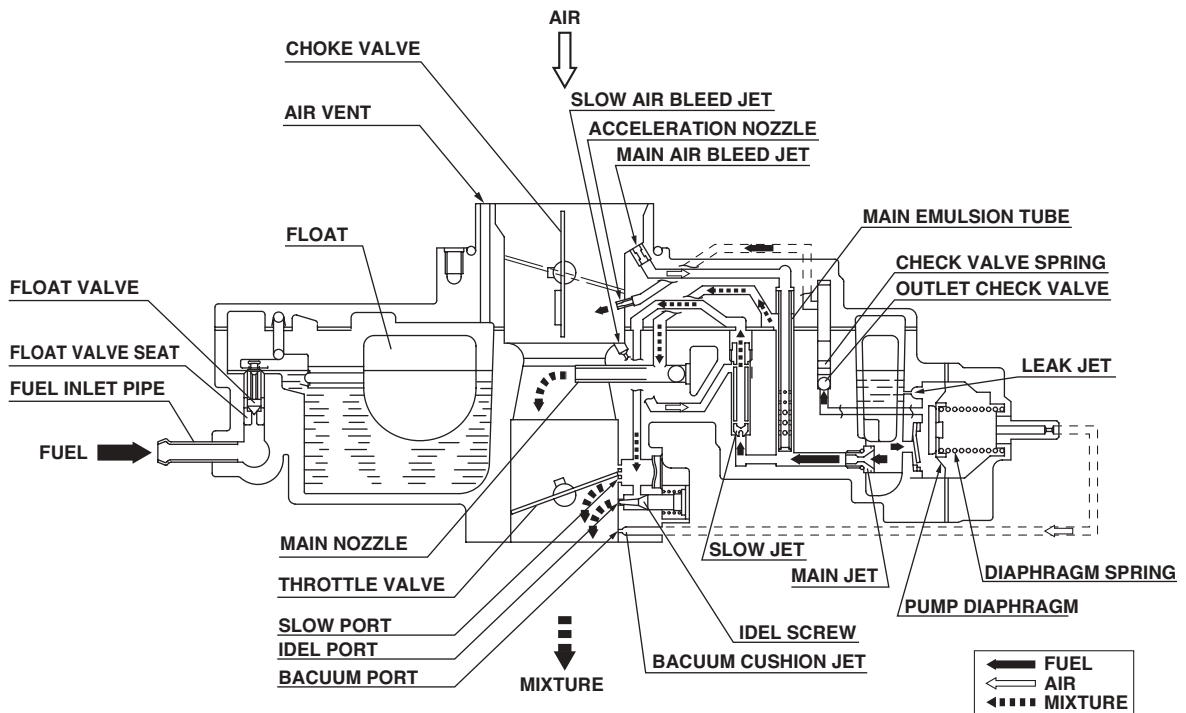



## **FLOAT SYSTEM**

The float system consists of a float and a needle valve, and maintains a constant fuel level during engine operation.

The fuel flows from the fuel tank into the float chamber through needle valve.

When the fuel rises to a specific level, the float rises, and when its buoyancy and fuel pressure are balanced, the needle valve closes to shut off the fuel, thereby keeping the fuel at the predetermined level.

Air vent hole of float chamber is provided around the carburetor air horn and the fuel vapor is sucked into the combustion chamber. This closed system has anti-dust feature.

## **PILOT SYSTEM**

The pilot system feeds the fuel to the engine during idling and low-speed operation.

The fuel is fed through the main jet to the pilot jet, where it is metered, and mixed with the air metered by the pilot air jet.

The fuel-air mixture is fed to the engine through the pilot outlet and the by-pass.

At idling speed, the fuel is mainly fed from the pilot outlet.

## **MAIN SYSTEM**

The main system feeds the fuel to the engine at medium-and high-speed operation.

The fuel is metered by the main jet and fed to the main nozzle. The air metered by the main air jet is mixed with the fuel through the emulsion tube, and the mixture is atomized out of the main bore. It is mixed again with the air taken through the air cleaner into an optimum fuel-air mixture, which is supplied to the engine.

## **CHOKE**

The choke is used for easy start when engine is cold.

When the starter is operated with a choke valve fully closed, the negative pressure applied to the main nozzle increases and draws much fuel accordingly; thus easily start up the engine.

## **ACCELERATOR-PUMP SYSTEM (EH72 only)**

When the throttle is opened rapidly for acceleration, air flow and manifold vacuum change almost instantaneously. Because fuel is heavy and lags behind air flow, a momentary leanness results. The accelerator-pump supplies extra fuel for smooth operation during this condition.

At constant load condition, a vacuum passage in the carburetor applies manifold vacuum to the pump diaphragm and the pump diaphragm is held to pull position.

When the throttle is opened rapidly for acceleration, the manifold vacuum is dropped, the pump diaphragm moves by the diaphragm spring, the fuel in the pump chamber push out by the pump diaphragm and the fuel gush out from the accelerator-pump nozzle.

## **FUEL CUT VALVE**

Fuel cut valve, operated with starter key switch, is equipped with main system of carburetor for preventing engine running on and after burning.

When the key switch is on, the valve is activated and the plunger is pulled in to open the main jet.

When the key switch is off, the power source to the valve is off. The plunger is pushed out by the return spring and stop the fuel flow of main jet.

## COMPORNENT PARTS

[EH63, 64, 65]

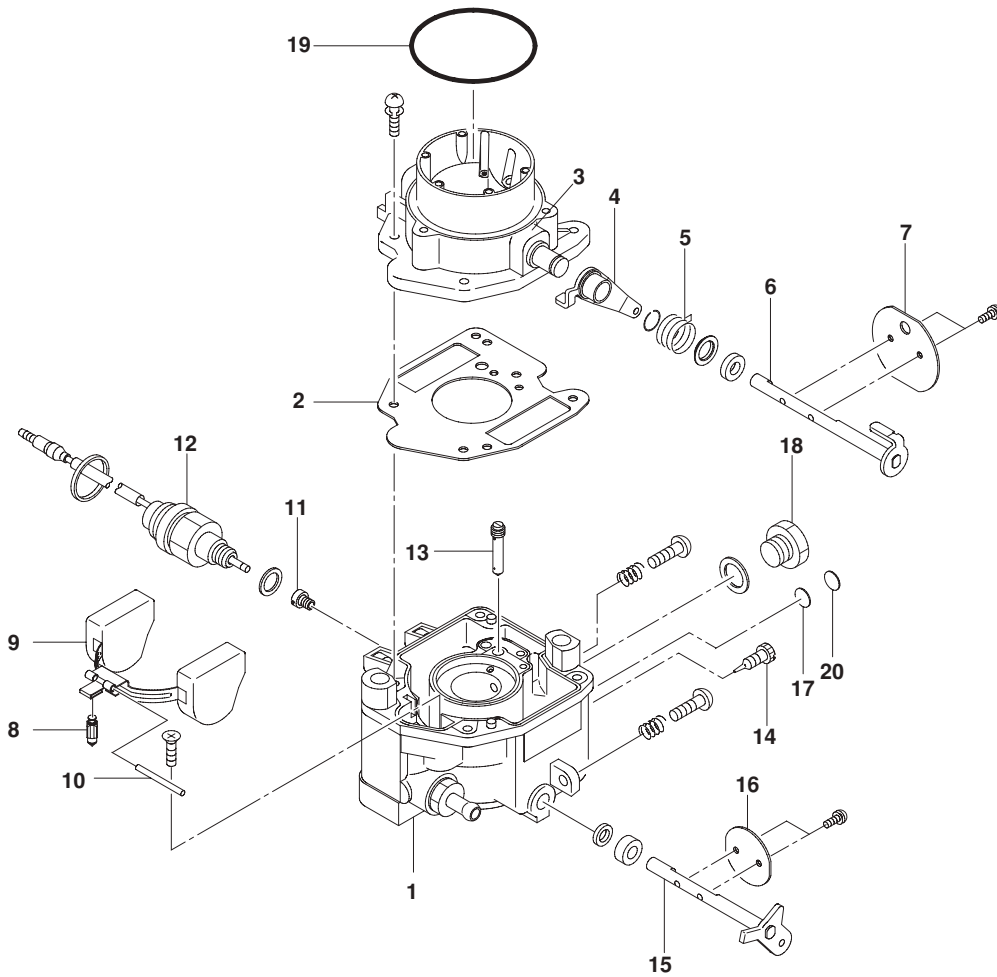

- |                       |                          |
|-----------------------|--------------------------|
| 1. BODY, lower        | 11. MAIN JET             |
| 2. GASKET, body upper | 12. SOLENOID VALVE ASS'Y |
| 3. BODY, upper        | 13. JET, slow            |
| 4. LEVER ASSY, choke  | 14. NEEDLE, idle adjust  |
| 5. SPRING, choke      | 15. THROTTLE SHAFT ASS'Y |
| 6. SHAFT ASSY, choke  | 16. THROTTLE VALVE       |
| 7. CHOKE VALVE        | 17. EXPANSION PLUG       |
| 8. VALVE, float       | 18. PLUG                 |
| 9. FLOAT ASSY         | 19. O-RING               |
| 10. FLOAT PIN         | 20. PLUG, anti tamper    |

[EH72]

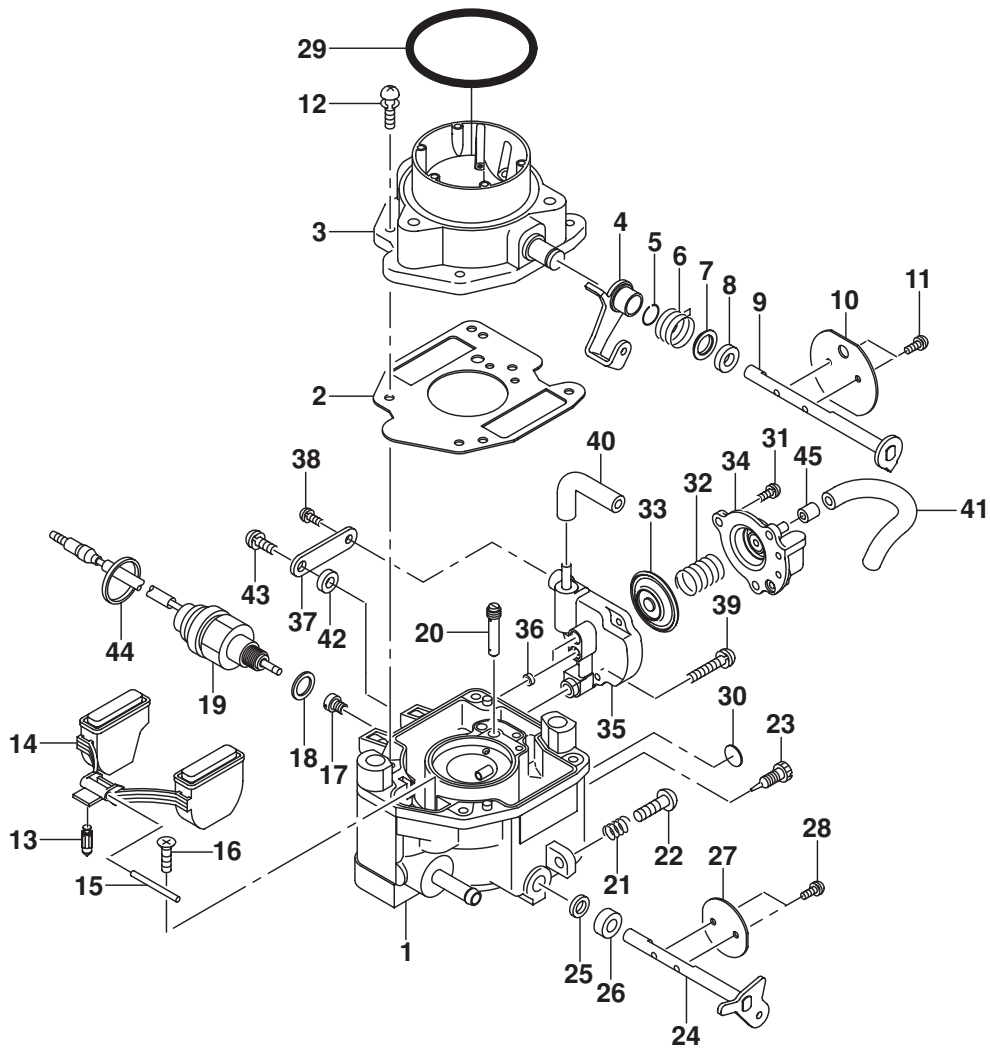

- |                         |                            |                            |
|-------------------------|----------------------------|----------------------------|
| 1. BODY, lower          | 16. SCREW, float pin set   | 31. SCREW and WASHER ASS'Y |
| 2. GASKET, air horn     | 17. MAIN JET               | 32. SPRING                 |
| 3. BODY, upper          | 18. GASKET                 | 33. DIAPHRAGM ASS'Y        |
| 4. LEVER ASS'Y, choke   | 19. SOLENOID VALVE ASS'Y   | 34. COVER ASS'Y            |
| 5. RING, choke lever    | 20. JET, slow              | 35. BODY ASS'Y             |
| 6. SPRING, choke        | 21. SPRING, adjust screw   | 36. U RING                 |
| 7. COLLAR, choke        | 22. SCREW, throttle adjust | 37. HOLDER                 |
| 8. FILTER, choke shaft  | 23. NEEDLE, idle adjust    | 38. SCREW and WASHER ASS'Y |
| 9. SHAFT ASS'Y, choke   | 24. THROTTLE SHAFT ASS'Y   | 39. SCREW, body set        |
| 10. CHOKE VALVE         | 25. FILTER, throttle shaft | 40. PIPE, connector        |
| 11. SCREW, valve set    | 26. COLLAR                 | 41. PIPE, connector        |
| 12. SCREW, air horn set | 27. THROTTLE VALVE         | 42. SPACER                 |
| 13. VALVE, float        | 28. VALVE SET SCREW        | 43. SCREW, holder set      |
| 14. FLOAT ASS'Y         | 29. O RING                 | 44. CLAMP, SOLENOID WIRE   |
| 15. FLOAT PIN           | 30. PLUG, ANTI TAMPER      | 45. JET                    |

# 8. ELECTRIC SYSTEM

## OPERATION AND FUNCTION

The ignition system is pointless flywheel magneto with automatic advancing characteristic.

Being different from the breaker point type ignition system, this system is completely free from such troubles as starting-up failure owing to dirty, burnt or corroded point surface.

The electronic automatic advancing ensures extremely easy starts and stable high performance at operating speed by advancing the ignition timing to the most suitable point.

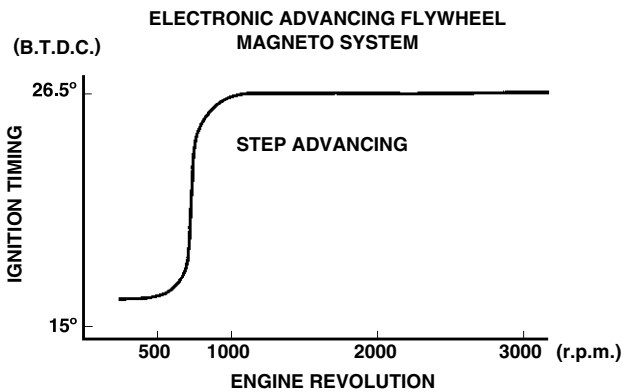
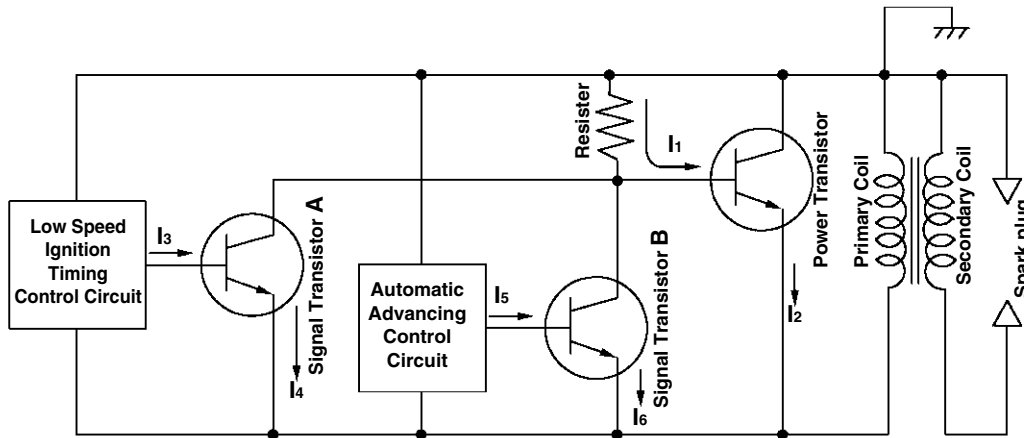

## BASIC THEORY

(1) Revolution of the flywheel generates electricity on the primary side of the ignition coil, and the base current  $I_1$  flows to the power transistor. Current  $I_1$  turns the power transistor "ON" and the electric current  $I_2$  flows.

(2) At lower engine revolution, when the flywheel reached the ignition point the low speed ignition timing control circuit operates to run the base current  $I_3$  to turn the signal transistor A "ON" allowing the current  $I_1$  to bypass as current  $I_4$ .

At this moment the power transistor turns "OFF" and the current  $I_2$  is abruptly shut resulting in the high voltage generated in the secondary coil which produces sparks at the spark plug.

(3) At higher engine revolution, the advancing control circuit operates at the ignition timing to run the base current  $I_5$  to turn the signal transistor B "ON" allowing the current  $I_1$  to bypass as current  $I_6$ . At this moment the power transistor turns "OFF" and the current  $I_2$  is abruptly shut resulting in the high voltage generated in the secondary coil which produces sparks at the spark plug. The operating timing of the advancing control circuit advances in accordance with the increase of engine speed resulting in the advancing of ignition timing.

## WIRING DIAGRAM

Connect key switch, magnetic switch and battery with wirings of proper gauge as shown by the dotted lines in the wiring diagram.

### Without Control box

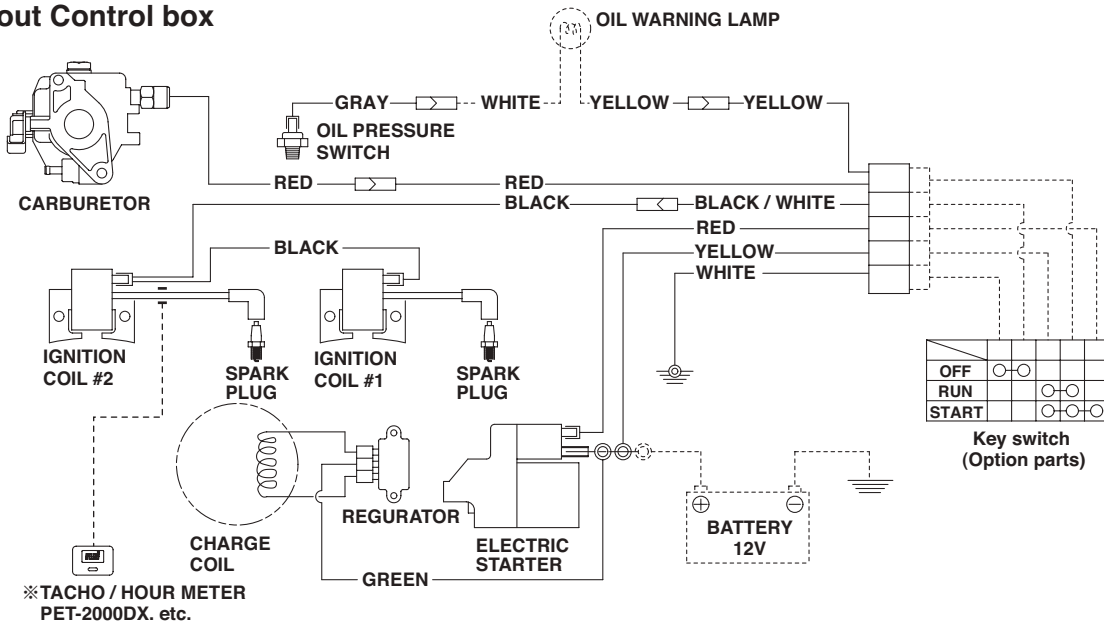

### With Control box

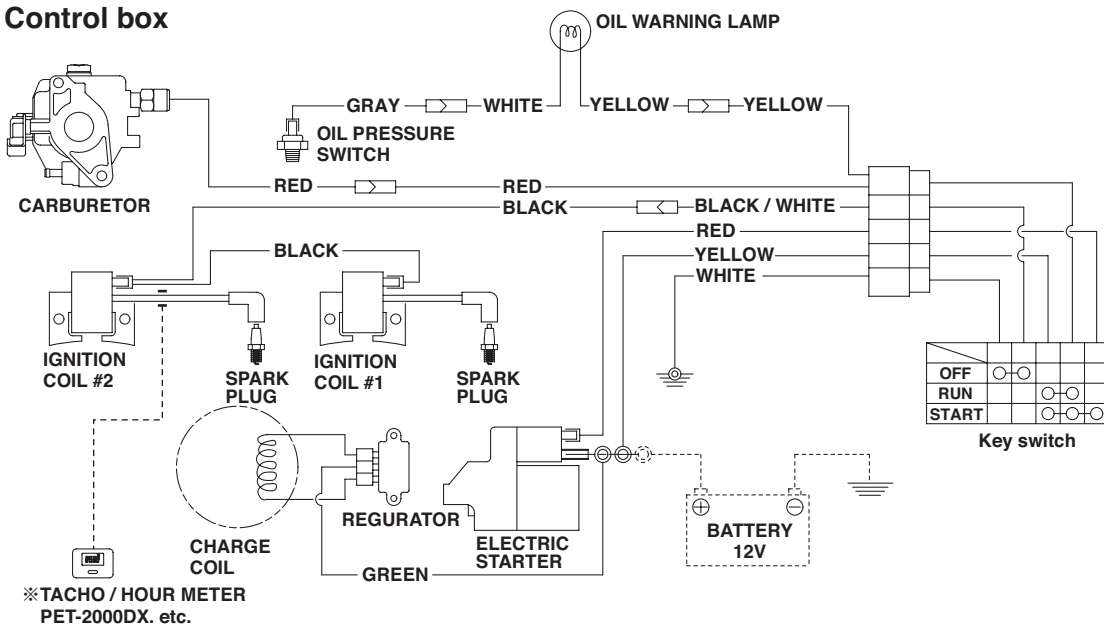

## ELECTRIC STARTER

When key switch is turned ON, lower electric current (M →) flows through coil of magnetic switch and the coil is excited. The plunger is pulled and higher current (S→) flows through electric starter.

When electric starter is operated, pinion gear is pushed out by means of centrifugal force of weight located in the spline of armature shaft. The pinion gear is engaged with ring gear and flywheel and crankshaft are rotated.

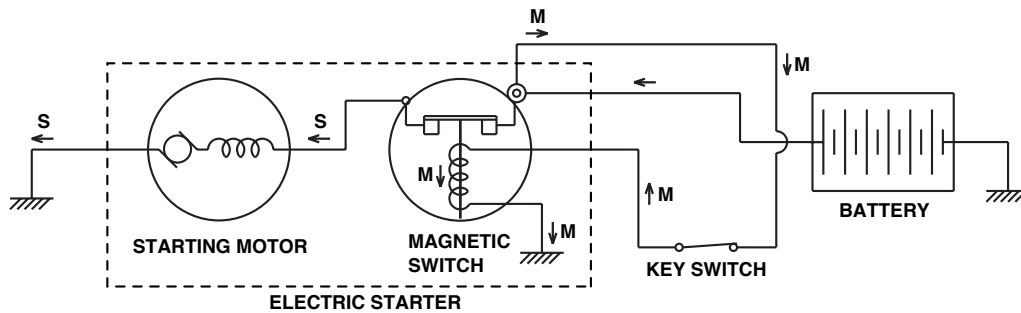

## COMPONENT PARTS

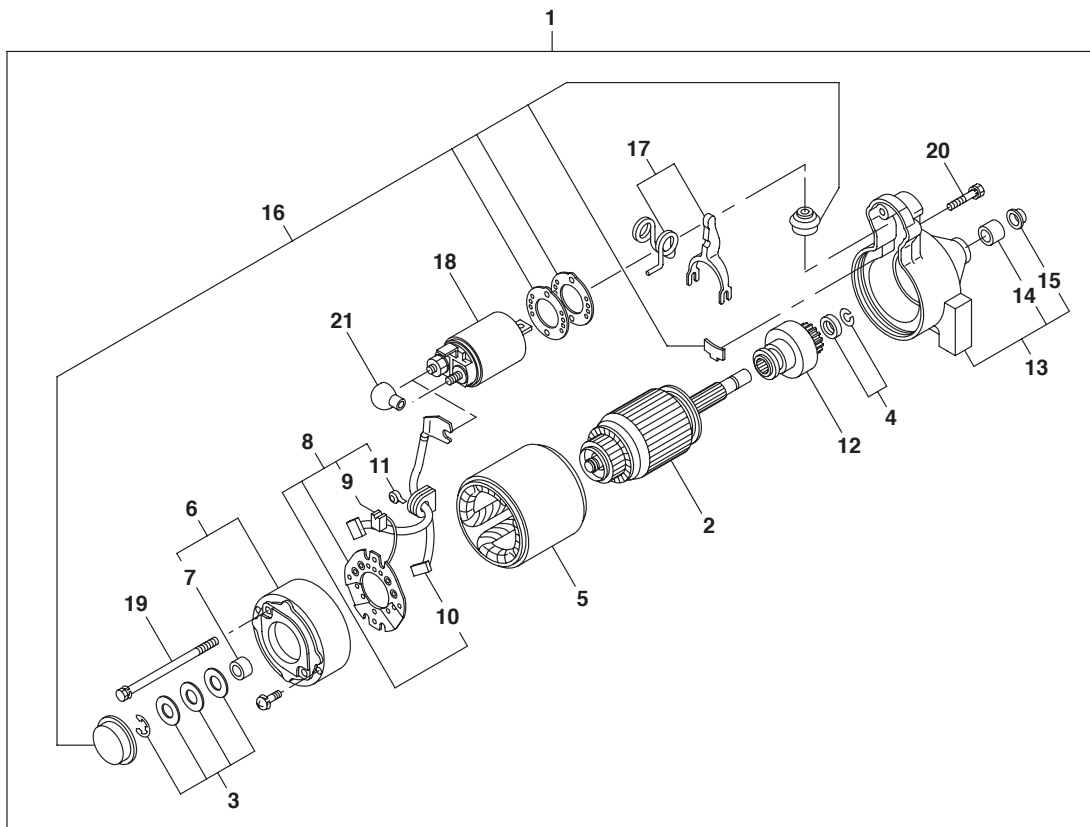

- |                         |                       |                           |
|-------------------------|-----------------------|---------------------------|
| 1. STARTING MOTOR ASS'Y | 8. BRUSH HOLDER ASS'Y | 15. GEAR CASE METAL COVER |
| 2. ARMATURE ASS'Y       | 9. BRUSH (-)          | 16. DUST COVER KIT        |
| 3. THRUST WASHER KIT    | 10. BRUSH SET         | 17. SHIFT LEVER KIT       |
| 4. PINION STOPPER SET   | 11. BRUSH SPRING      | 18. MAGNETIC SWITCH ASS'Y |
| 5. YOKE ASS'Y           | 12. PINION ASS'Y      | 19. THROUGH BOLT          |
| 6. REAR COVER ASS'Y     | 13. GEAR CASE ASS'Y   | 20. BOLT                  |
| 7. STARTER METAL        | 14. STARTER METAL     | 21. M TERMINAL COVER      |

## SPARK PLUG CAP

- Check continuity with a circuit tester.
- Spark plug cap has no resistor.
- If there is no continuity, replace the spark plug cap.

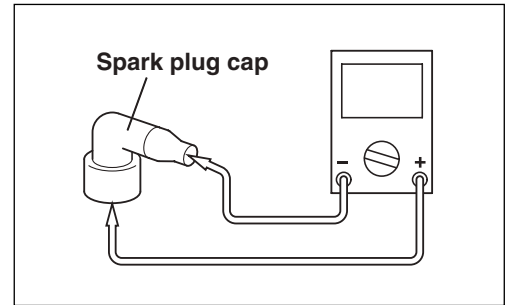

## SPARK PLUG

Sparking performance **(a)**: Over 6.0 mm (0.236 in.)  
Electrode gap **(b)**: 0.7 to 0.8 mm (0.028 - 0.031 in.)

- Check the sparking performance with an ignition checker.
  - ① Spark plug cap
  - ② To spark plug or Engine body earth
- Start cranking in the same way as starting the engine and inspect whether spark is greater than the rated value.

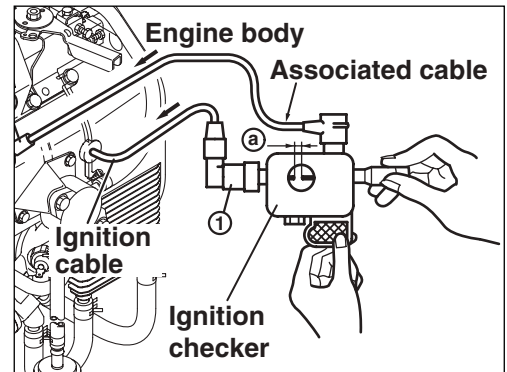

In case of no spark or sparking performance a is less than 6 mm (0.236 in.)

- Clean the spark plug.
- Adjust the electrode gap.
- Replace the spark plug.
- Check the ignition coil (next page).

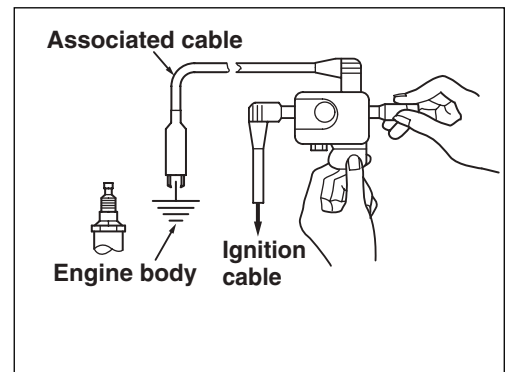
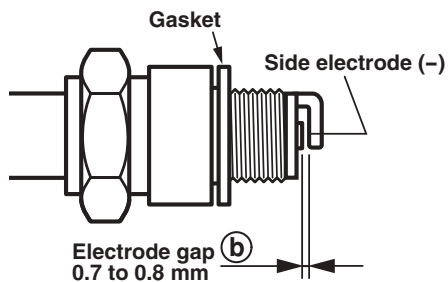

## IGNITION COIL

- Adjust the air gap between the ignition coil and flywheel using a thickness gauge and tighten bolts.

Ignition coil air gap
0.3 - 0.5 mm (0.012 - 0.020 in.)

Measure the resistance between the wires and core.

Resistance		
	High-tension cable (Secondary) ①	Stop wire (Primary) ②
Core	8 - 16 k $\Omega$	0 - 5 $\Omega$

- Replace the ignition coil if the actual resistance value greatly differs from the rated value. ( $\Omega \pm 20\%$  when 20°C)

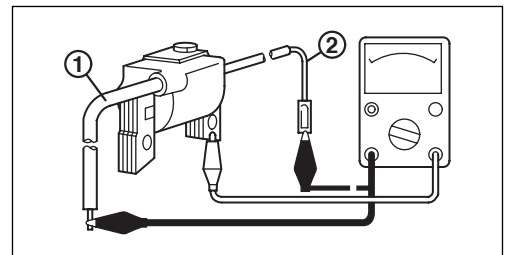
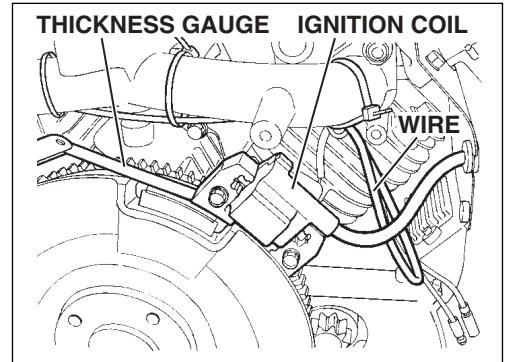

## CHARGE COIL

- Measure the resistance between the wires (① and ②).

Resistance
0.2 $\Omega$

- Replace the charge coil if the actual resistance value differs from the rated value. ( $\Omega \pm 20\%$  when 20°C)

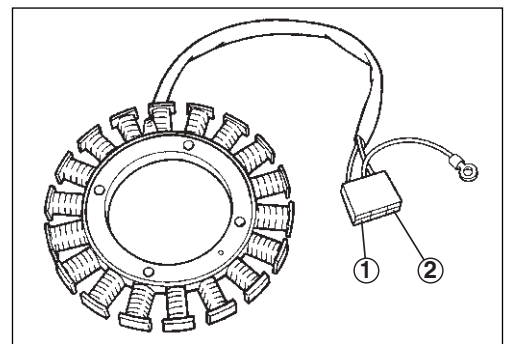



## REGULATOR

- Measure the resistance between the wires.  
Rated resistance value: ( $\Omega \pm 20\%$  when  $20^\circ\text{C}$ )

		Apply black (-) needle of the circuit tester			
		A	B	C	D
Apply red (+) needle of the circuit tester	A		200 to 300 $\Omega$	200 to 300 $\Omega$	$\infty$
	B	$\infty$		0 $\Omega$	$\infty$
	C	$\infty$	0 $\Omega$		$\infty$
	D	$\infty$	50 $\Omega$	50 $\Omega$	

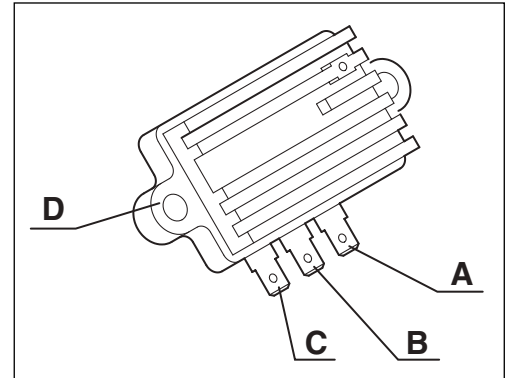

- Replace the regulator if the actual resistance value differs from the rated value.

## OIL PRESSURE SWITCH

**Switching Pressure : 1.0 kg/cm<sup>2</sup>  $\pm$  0.3**

- Inspect the switch action.
- The structure of the oil pressure switch is shown in a right figure. When there is no pressure (no oil), the diaphragm is pressed in by the spring, resulting in the contact being ON. If the oil pressure rises above the switching pressure, the diaphragm is pressed in by the oil pressure which is greater than the spring pressure, resulting in the contact being OFF.

**When engine is stopped : 0  $\Omega$  (continuity)**

**When engine is running :  $\infty$  (no continuity)**

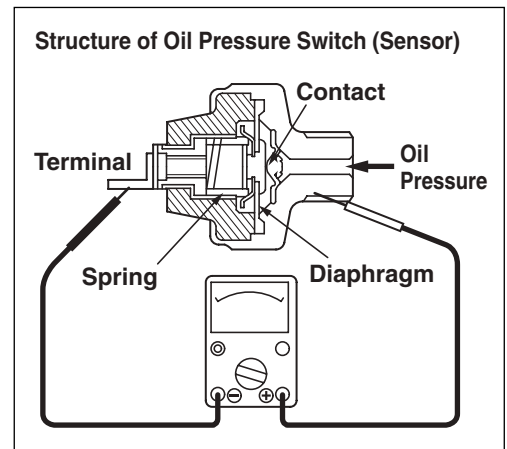

- The switch's structure is complicated, so if its function cannot be recovered even by cleaning, replace the switch with a new one.

## SOLENOID

**(for Fuel Cut Off of Carburetor)**

- Measure the resistance between the cable and body (body earth). ( $\Omega \pm 10\%$  when  $20^\circ\text{C}$ )

Resistance
38 $\Omega$

- Check the operation of the solenoid independently.  
Check operation at the cable(+) and the body(-). (Applied voltage : 8V)  
Faulty operation → Replace the solenoid
- As the solenoid is a constant pull-in type when the engine is running, If the battery's power is low, it may not work when starting the engine because all the available electricity is occupied by the starting motor.  
→ Charge or replace the battery.

Reference: Solenoid pull-in force: 0.3 kg/cm<sup>2</sup>

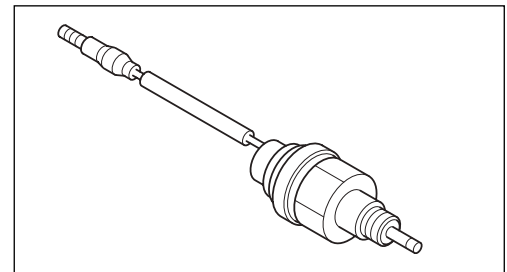

## 9. TROUBLESHOOTING

The following three conditions must be fulfilled for satisfactory engine start.

- (1) The cylinder filled with a proper fuel-air mixture.
- (2) Good compression in the cylinder.
- (3) Good spark, properly timed, to ignite the mixture.

The engine cannot be started unless these three conditions are met.

There are also other factors which make engine start difficult, e.g., a heavy load on the engine when it is about to start at low speed, and a high back pressure due to a long exhaust pipe.

The most common causes of engine troubles are given below:

### 9-1 NO ENGINE OPERATION

Phenomenon	Possible causes	Remedy
1. Electric starter does not operate.	1) Poor connection of key switch wiring	Check, repair or replace
	2) Wiring discontinuity between key switch and starter motor	Replace
	3) Wiring discontinuity between battery and starter motor	Replace
	4) Improper battery (low capacity) or discharged battery	Charge or replace battery
	5) Poor connection of battery terminal	Check, clean or replace
	6) Starter magnetic switch faulty	Check, clean, repair or replace
	7) Starter motor faulty	Repair or replace
	8) Crankshaft seizure	Check, repair or replace
	9) Seizure between piston and cylinder	Check, repair or replace
2. Electric starter operates, but engine does not start.	1) No fuel	Refill
	2) Poor connection or discontinuity of ignition system wirings	Check, repair or replace
	3) Electric starter faulty	Repair or replace

## 9-2 STARTING DIFFICULTIES

Phenomenon	Possible causes	Remedy
1. Low engine speed at starting	1) Battery discharged	Charge battery
	2) Poor connection between battery and starter motor	Clean or repair
	3) Poor connection between battery and ground	Clean or repair
	4) Electric starter faulty	Repair or replace
	5) Improper engine oil	Replace with recommended engine oil
2. Ignition system malfunction	Spark plug * Improper spark plug gap * No insulation * Carbon deposits	Adjust Replace Clean
	Ignition coil * No insulation or discontinuity * Poor connection or discontinuity of ignition code	Replace Repair or replace
	Improper air gap between ignition coil and flywheel	Adjust
3. Fuel system malfunction	1) No fuel in fuel tank	Refill
	2) Fuel pump clogged	Clean
	3) Fuel hose clogged or pinched	Clean or replace
	4) Air mixing into fuel lines	Check and adjust connecting portion
	5) Improper gasoline or water infiltration	Replace
	6) Carburetor * Overflow * Clogged or damaged * Improper operation of throttle valve	Adjust Disassembly and clean Check and adjust
	7) Poor connection of fuel cut valve wiring	Check and repair
4. Engine core components malfunction	1) Insufficient tightening of cylinder head bolts	Check and retighten
	2) Wear of piston, piston ring and/or cylinder	Repair or replace
	3) Improper contact of valve and seat	Repair
	4) Valve seizure	Repair
	5) Improper valve clearance	Adjust
	6) Intake manifold gasket leakage	Retighten intake manifold bolts or replace gasket
	7) Carburetor gasket leakage	Retighten carburetor bolts or replace gasket
	8) Insufficient tightening of spark plug	Retighten

### 9-3 INSUFFICIENT OUTPUT

Phenomenon	Possible causes	Remedy
1. Low compression	1) Loosen spark plug	Retighten or replace gasket
	2) Cylinder head gasket leakage	Retighten or replace gasket
	3) Piston ring(s) seizure or wear	Replace
	4) Piston or cylinder wear	Repair or replace
	5) Incorrect valve and seat contact	Repair or replace
	6) Valve stem seizure	Repair or replace
	7) Improper valve clearance	Adjust
2. Ignition system malfunction	1) Spark plug faulty	Replace
	2) Ignition coil faulty	Replace
	3) Improper air gap between ignition coil and flywheel	Adjust
	4) Magneto demagnetization	Replace
3. Fuel system malfunction	1) Carburetor clogged	Disassembly and clean
	2) Improper fuel pump operation	Disassembly and clean
	3) Fuel strainer or fuel hose clogged	Clean or replace
	4) Air mixing into fuel lines	Check and adjust connecting portion
	5) Improper gasoline or water infiltration	Replace
4. Low intake air volume	1) Air cleaner clogged	Clean or replace
	2) Throttle valve faulty	Repair or replace

### 9-4 OVERHEAT

Phenomenon	Possible causes	Remedy
Overheating	1) Cooling air flow obstructed at inlet or cylinder baffle portion	Clean
	2) Improper engine oil	Replace
	3) Lean air/fuel mixture	Check and adjust carburetor
	4) Excessive back pressure of exhaust system	Check, clean or replace
	5) Over-load	Change to rated load

## 9-5 ROUGH IDLING

Phenomenon	Possible causes	Remedy
1. Carburetor	1) Low idling speed	Adjust
	2) Carburetor slow system passage clogged	Check and clean
2. Intake system	1) Air mixing from connecting portion of air intake system	Check, tighten or replace gasket
3. Cylinder head	1) Cylinder head gasket faulty (blow-by)	Replace
4. Valve system	1) Improper valve clearance	Adjust
	2) Leakage from valve seat	Adjust valve seat contact
	3) Excessive clearance between valve stem and guide	Replace
5. Ignition system	1) Weak ignition spark	Check and replace spark plug

## 9-6 HIGH ENGINE OIL CONSUMPTION

Phenomenon	Possible causes	Remedy
1. Oil leakage	1) Loosen drain plug	Tighten
	2) Drain plug gasket damaged	Replace
	3) Incorrect oil filter fitting	Repair
	4) Loosen main bearing cover bolts	Tighten
	5) Main bearing cover gasket damaged	Replace
	6) Crankshaft oil seal damaged	Replace
2. Oil dilution	1) Piston oil ring faulty	Replace
	2) Piston rings seizure, wear or poor contact	Replace
	3) Excessive wear of piston and cylinder	Replace
	4) Excessive wear of valve stem	Replace
	5) High oil level	Adjust oil level
	6) Breather faulty	Repair or replace

## 9-7 HIGH FUEL CONSUMPTION

Phenomenon	Possible causes	Remedy
1. Fuel system	1) Over-size main jet	Replace
	2) Needle valve faulty and/or high fuel level in float chamber	Adjust or replace
	3) Chock valve does not open fully.	Repair or replace
2. Engine core components	1) Low compression	Check or repair
	2) Over cooling	Check and adjust load and/or engine speed

## 9-8 DETONATION

Phenomenon	Possible causes	Remedy
1. Ignition system malfunction	1) Poor connection of ignition system wirings	Check and connect properly
	2) Improper or damaged spark plug	Clean or replace
2. Fuel system malfunction	1) Lean or rich air/fuel mixture	Clean, adjust or replace
	2) Carburetor damaged	Disassembly and clean
	3) Fuel lines clogged or damaged	Clean or replace
	4) Air mixing from connecting portion of air intake system	Connect properly or replace gasket
3. Cylinder head	1) Carbon deposit in combustion chamber	Remove and clean
	2) Cylinder head gasket faulty (blow-by)	Replace
4. Valve system	1) Improper valve clearance	Adjust
	2) Valve heat deterioration	Replace
	3) Valve spring deterioration	Replace
	4) Improper valve timing	Adjust

## 9-9 ENGINE MISFIRE

Phenomenon	Possible causes	Remedy
1. Ignition system	1) Improper spark plug gap or damaged electrode	Cealn, adjust or replace
	2) Ignition coil faulty	Replace
	3) Damaged ignition system wirings	Replace
	4) Poor connection of ignition system wirings	Check and connect properly
2. Fuel system	1) Lean or rich air/fuel mixture	Disassembly and repair
	2) Carburetor clogged	Disassembly and repair
	3) Improper idling adjustment of carburetor	Adjust
	4) Improper gasoline or water infiltration	Replace
3. Engine core componets	1) Valve heat deterioration or improper valve adjustment	Adjust or replace
	2) Valve spring deterioration	Replace
	3) Low compression	Check, adjust or replace

# 10. INSTALLATION

Engine life, ease of maintenance and inspection, frequency of checks and repairs, and operating cost all depend on the way in which the engine is installed. Review the following instructions carefully for installing the engine.

## 10-1 INSTALLING

When mounting the engine, carefully examine its position, the method of connecting it to a machine, the foundation, and the method of supporting the engine.

When determining its mounting position, in particular, make sure that gasoline and oil can easily be supplied and checked, the spark plug can easily be checked, the air cleaner can easily be serviced, and that the oil can easily be discharged.

## 10-2 VENTILATION

Fresh air is necessary for cooling the engine and burning the fuel.

In the case the engine is operated under a hood or in a small room, temperature rise in the engine room can cause vapor lock, oil deterioration, increased oil consumption, loss of power, piston seizure, shorter engine life, etc., making it impossible to operate the engine properly. It is necessary, therefore, to provide a duct or baffle to guide cooling air to the engine to prevent recirculation of the hot air used for engine cooling, and temperature rise of the machine.

Keep the engine room temperature below 50°C even in the hottest period of the year.

## 10-3 EXHAUST GAS DISCHARGE

Exhaust gas is noxious. When operating the engine indoors, be sure to discharge the exhaust gas outdoors. If a long exhaust pipe is used in such a case, the internal resistance increases causing loss of engine power. Thus pipe inside diameter must be increased in proportion to exhaust pipe length.

Exhaust pipe :   Less than 3 m long --- pipe inside diameter 30 mm.  
                          Less than 5 m long --- pipe inside diameter 33 mm.

## 10-4 POWER TRANSMISSION TO DRIVEN MACHINES

### 10-4-1 BELT DRIVE

Take the following notes into consideration.

- \* V-belts are preferable to flat belts.
- \* The driving shaft of the engine must be parallel to the driven shaft of the machine.
- \* The driving pulley of the engine must be in line with the driven pulley of the machine.
- \* Install the engine pulley as close to the engine as possible.
- \* If possible, span the belt horizontally.
- \* Disengage the load when starting the engine.

If no clutch is used, use a belt tension pulley or the like.

### 10-4-2 FLEXIBLE COUPLING

When using a flexible coupling, run out and misalignment between the driven shaft and engine shaft must be minimized. Run out and misalignment tolerance are specified by the coupling manufacturer.



# 11. SERVICE DATA

"STD" in the following table is the parts dimension from the brand new engine or the spare parts. Whereas, "Limit" shows the maximum allowance for the parts to be used on the engine. If the measurement exceeds beyond the "Limit", the part needs to be replaced and/or repaired.

## 11-1 STANDARD DIMENSIONS AND SERVICE LIMITS

Unit : mm(in.)

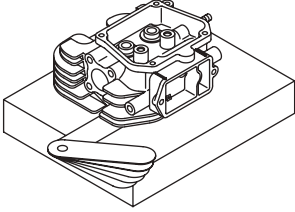
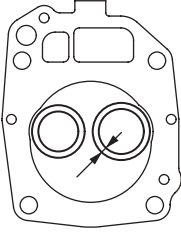
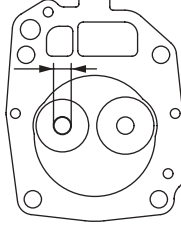
ITEM		STD	Limit		
CYLINDER HEAD * Flatness 		EH63 EH64 EH65 EH72	0.05 or less (0.002 or less)	0.1 (0.004)	
	* Valve seat contact width 	IN. EX.	EH63 EH64 EH65 EH72	0.7 - 1.0 (0.028 - 0.039)	2.0 (0.079)
	* Valve guide inside dia. 	IN. EX.	EH63 EH64 EH65 EH72	6.035 - 6.053 (0.2376 - 0.2383)	6.15 (0.242)

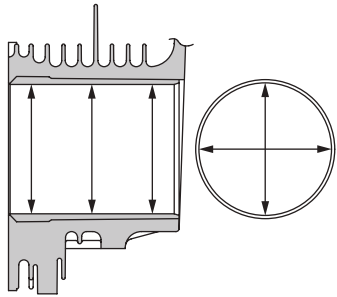
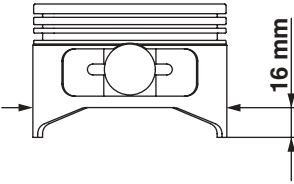
ITEM		STD	Limit		
<b>CYLINDER</b> * Inside dia. 	STD	EH63 EH64 EH65	80.000 - 80.019 (3.1496 - 3.1504)	To be rebored when the difference between max. and min. of diameter reached to 0.1 (0.004).	
		EH72	84.000 - 84.022 (3.3071 - 3.3080)		
	1st reboring	EH63 EH64 EH65	80.250 - 80.269 (3.159 - 3.160)	Ditto	
		EH72	84.250 - 84.272 (3.3169 - 3.3178)		
	2nd reboring	EH63 EH64 EH65	80.500 - 80.519 (3.169 - 3.170)	—	
		EH72	84.500 - 84.522 (3.3268 - 3.3276)		
	* Roundness after reboring.	EH63 EH64 EH65 EH72	0.01 (0.0004)	—	
	* Cylindricity after reboring.	EH63 EH64 EH65 EH72	0.015 (0.0006)	—	
	<b>PISTON</b> * Piston size (At skirt in thrust direction) 	STD	EH63 EH64 EH65	79.968 - 79.988 (3.148 - 3.149)	79.878 (3.145)
			EH72	83.980 - 84.000 (3.3063 - 3.3071)	83.890 (3.3028)
1st o/s		EH63 EH64 EH65	80.218 - 80.238 (3.158 - 3.159)	80.128 (3.155)	
		EH72	84.230 - 84.250 (3.3161 - 3.3169)	84.140 (3.3126)	
2nd o/s		EH63 EH64 EH65	80.468 - 80.488 (3.168 - 3.169)	80.378 (3.164)	
		EH72	84.480 - 84.500 (3.3260 - 3.3268)	84.390 (3.3224)	

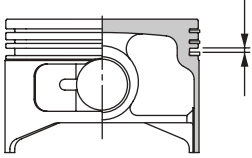
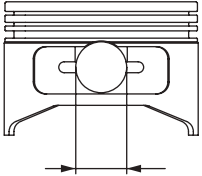
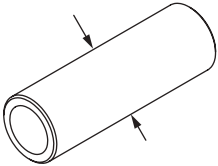
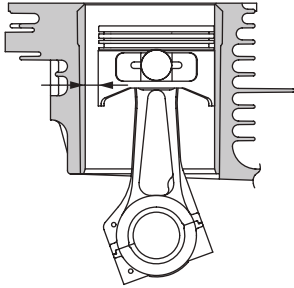
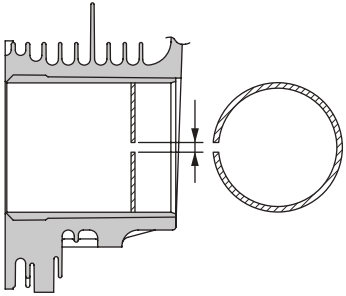
ITEM		STD	Limit
PISTON * Ring groove side clearance 	Top	EH63 EH64 EH65 EH72 0.05 - 0.09 (0.0002 - 0.0035)	0.15 (0.006)
	2nd	EH63 EH64 EH65 EH72 0.03 - 0.07 (0.0012 - 0.0028)	0.15 (0.006)
	Oil ring	EH63 EH64 EH65 EH72 0.057 - 0.175 (0.0022 - 0.0069)	0.15 (0.006)
* Piston pin hole 		EH63 EH64 EH65 EH72 20.989 - 21.002 (0.8263 - 0.8269)	21.035 (0.8281)
* Piston pin outside dia. 		EH63 EH64 EH65 EH72 20.991 - 21.000 (0.8264 - 0.8268)	20.960 (0.8251)
* Clearance between piston and cylinder at skirt area. 		EH63 EH64 EH65 0.012 - 0.051 (0.0005 - 0.0020)	0.25 (0.0098)
		EH72 0 - 0.042 (0 - 0.001654)	0.25 (0.0098)
* Piston ring end gap 	Top 2nd	EH63 EH64 EH65 EH72 0.2 - 0.4 (0.0079 - 0.0157)	1.5 (0.0591)
	Oil ring	EH63 EH64 EH65 EH72 0.2 - 0.7 (0.0079 - 0.0276)	1.5 (0.0591)

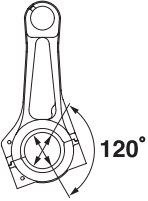
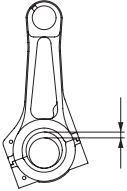
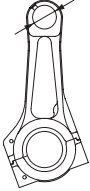
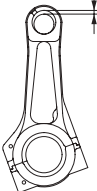
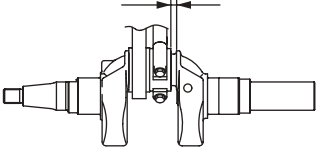
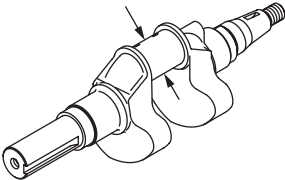
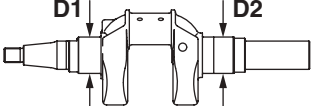
ITEM		STD	Limit
CONNECTING ROD * Big end inside dia.		EH63 EH64 EH65 EH72 39.000 - 39.016 (1.5354 - 1.5361)	39.100 (1.5394)
* Clearance between big end and crankpin		EH63 EH64 EH65 EH72 0.030 - 0.060 (0.0012 - 0.0024)	0.2 (0.079)
* Small end inside dia.		EH63 EH64 EH65 EH72 21.010 - 21.023 (0.8272 - 0.8277)	21.080 (0.8299)
* Clearance between small end and piston pin		EH63 EH64 EH65 EH72 0.010 - 0.032 (0.0004 - 0.0013)	0.12 (0.0047)
* Big end side clearance		EH63 EH64 EH65 EH72 0.1 - 0.4 (0.0039 - 0.0127)	1.0 (0.0394)
CRANKSHAFT * Crankpin outside dia.		EH63 EH64 EH65 EH72 38.956 - 38.970 (1.5337 - 1.5343)	38.90 (1.5315)
* Journal dia.		EH63 EH64 EH65 EH72 D1: 44.984 - 45.000 (1.77102 - 1.77165) D2: 44.986 - 44.997 (1.77110 - 1.77154)	—

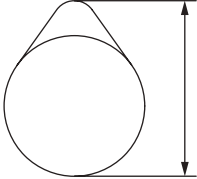
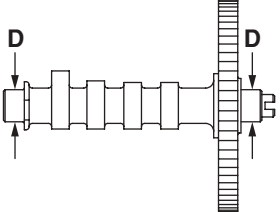
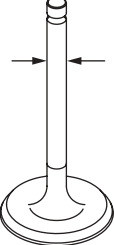
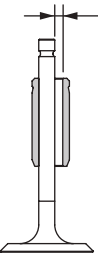
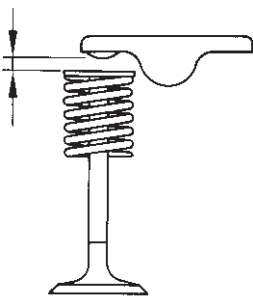
ITEM		STD	Limit		
<b>CAMSHAFT</b> * Cam height (IN. and EX.) 	EH63 EH64 EH65 EH72	35.35 - 35.37 (1.392 - 1.393)	35.20 (1.385)		
		* Journal outside dia. "D" type 	EH63 EH64 EH65 EH72	19.967 - 19.980 (0.7861 - 0.7866)	19.950 (0.7854)
<b>VALVE</b> * Valve stem outside dia. 	IN.	EH63 EH64 EH65 EH72	5.970 - 5.985 (0.2350 - 0.2356)	5.85 (0.2303)	
	EX.	EH63 EH64 EH65 EH72	5.970 - 5.985 (0.2350 - 0.2356)	5.85 (0.2303)	
	* Clearance between valve stem dia. and valve guide 	IN.	EH63 EH64 EH65 EH72	0.050 - 0.083 (0.00197 - 0.00327)	0.30 (0.0118)
		EX.	EH63 EH64 EH65 EH72	0.050 - 0.083 (0.00197 - 0.00327)	0.30 (0.0118)
* Valve clearance 	IN. / EX. (cold)	EH63 EH64 EH65 EH72	0.07 - 0.13 (0.003 - 0.005)		

Unit : mm(in.)

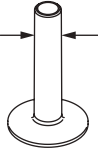
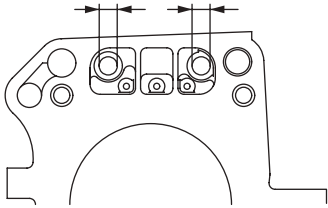
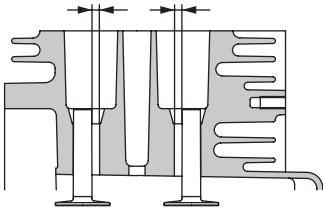
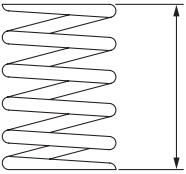
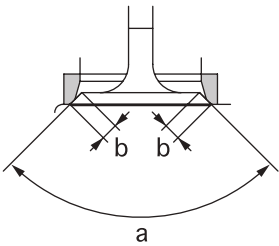
ITEM		STD	Limit
<b>TAPPET</b> * Stem outside dia.   * Guide inside dia.   * Tappet guide clearance 	EH63 EH64 EH65 EH72	8.954 - 8.979 (0.3525 - 0.3535)	8.924 (0.3513)
	EH63 EH64 EH65 EH72	9.00 - 9.015 (0.3543 - 0.3549)	9.08 (0.3575)
	EH63 EH64 EH65 EH72	0.021 - 0.061 (0.000827 - 0.002402)	0.15 (0.0059)
<b>VALVE SPRING FREE LENGTH</b> 	EH63 EH64 EH65 EH72	39.5 (1.5551)	—
<b>VALVE SEAT ANGLE (IN. EX.)</b> * Valve cutter angle (a) * Valve contact width (b) 	EH63 EH64 EH65 EH72	a: 90° b: 0.7 - 1.0 (0.028 - 0.039)	2.0 (0.079)

		EH63	EH64	EH65	EH72
Compression pressure	(kg / cm <sup>2</sup> 470 rpm )	12			
Fuel consumption	Continuous load / 3600 rpm (L/Hr)	5.5	5.8	6.0	7.0
Lubricant	Capacity (L)	1.55			
	Efficacy (mL)	620			
	Consumption (mL / Hr)	12 - 15			15 - 20

※1 Above values are rough standard.

They will be changed by the engine condition and the environment.

※2 Oil consumption has been measured under-following condition:

- Good break-in operation has been finished.
- Oil : 10W-30 (Grade SE)
- Load : Continuous load / 3600 rpm

## 11-2 TIGHTENING TORQUE

ITEMS		Tightening Torque		
		N·m	kgf · cm	ft·lb.
Breather cover		2.9 - 4.9	30 - 50	2.2 - 3.6
Carburetor bolts		16.6 - 18.6	170 - 190	12.3 - 13.7
Charge coil		2.9 - 3.9	30 - 40	2.2 - 2.9
Connecting rod cap bolts		22 - 27	225 - 275	16.3 - 19.8
Cylinder head bolts		41 - 49	400 - 500	30.2 - 36.1
Flywheel nut		100 - 120	1020 - 1220	73.8 - 88.5
Ignition coil		6.8 - 8.8	70 - 90	5.0 - 6.5
Intake manifold bolts		16.6 - 18.6	170 - 190	12.3 - 13.7
Main bearing cover bolts		22.5 - 27.5	230 - 280	16.5 - 20.2
Oil filter		9.9 - 14.7	100 - 150	7.3 - 10.8
Oil pressure switch		5.9 - 9.8	60 - 100	4.3 - 7.2
Oil relief plug		14.7 - 24.5	150 - 250	10.8 - 18.0
Rocker arm	Lock nut	6.8 - 8.8	70 - 90	5.0 - 6.5
	Pivot bolt	16.6 - 18.6	170 - 190	12.3 - 13.7
Rocker cover		6.8 - 8.8	70 - 90	5.0 - 6.5
Spark plug	New one	11.7 - 14.7	120 - 150	8.6 - 10.8
	Current one	22.1 - 26.9	225 - 275	16.3 - 19.8
Starter motor bolts		16.6 - 18.6	170 - 190	12.3 - 13.7

# 12. MAINTENANCE AND STORAGE

## 12-1 DAILY MAINTENANCE

Every day before operating engine, check the following items :

MAINTENANCE ITEMS	REMARKS
1) Clean away dust and chaff from engine.	Governor linkage is especially sensitive to dust.
2) Check fuel leakage from fuel system. If any, retighten fasteners or replace necessary parts.	
3) Inspect for loose hardware and retighten if necessary.	Loose bolts and nuts may come off and result in breakage of other parts.
4) Check oil level and add to full level.	

## 12-2 PERIODIC MAINTENANCE SCHEDULE

Periodic maintenance is vital to safe and efficient operation of engine.

Check the table below for periodic maintenance intervals.

It is also necessary to conduct the maintenance and adjustments on the emission-related parts listed below to keep the emission control system effective;

- (1) Carburetor and internal parts
- (2) Choke system
- (3) Fuel strainer
- (4) Air cleaner elements
- (5) Intake pipe
- (6) Spark plug
- (7) Magneto
- (8) Fuel hoses, clamps and sealing gaskets

The following maintenance schedule is based on the normal engine operation.

Should the engine be operated in extremely dusty condition or in heavier loading condition, the maintenance interval must be shortened depending on the contamination of oil, clogging of filter elements, wear of parts, and so on.



## Periodic Maintenance Schedule table

Maintenance Items	Every 8 hours (Daily)	Every 50 hours (Weekly)	Every 200 hours (Monthly)	Every 500 hours	Every 1000 hours
Clean engine and check bolts and nuts	● (Daily)				
Check and refill engine oil	● (Refill daily up to upper level)				
Change engine oil (*Note : 1)	● (Initial 20 hours)	● (Every 100 hours)			
Replace engine oil filter (*Note 1)	● (Initial 20 hours)		●		
Check battery electrolyte fluid level		●			
Clean spark plug		●			
Clean air cleaner		●			
Clean spark arrester (Optional part)		● (Every 100 hours)			
Replace air cleaner element			●		
Clean fuel strainer			●		
Clean and adjust spark plug and electrodes			●		
Replace spark plug				●	
Remove carbon from cylinder head				●	
Clean and adjust carburetor				●	
Clean engine base (oil pan)				●	
Check and adjust valve clearance				●	
Replace fuel lines					● (Yearly)
Overhaul engine (*Note : 2)					●

\*Note : 1. Initial oil change and oil filter replacement should be performed after 20 hours of operation. Thereafter change oil every hundred (100) hours and replace oil filter 200 hours. Before changing oil, check for a suitable way to dispose of old oil. Do not pour it down into sewage drains, onto garden soil or into open streams. Your local zoning or environmental regulations will give you more detailed instructions on proper disposal.

\*Note : 2. As to the procedures, please refer to the Service Manual or consult your nearest service dealer.

\*Note : 3. More frequent oil changing, oil filter replacement and air cleaner service on replacement may be necessary depending on operating conditions. This would include dusty environment, high ambient temperature, heavy engine loading.

## 12-3 SPARK ARRESTER (OPTIONAL)

In a dry or wooded area, it is recommendable to use the product with a spark arrester. Some areas require the use of a spark arrester. Please check your local laws and regulations before operating your product.

The spark arrester must be cleaned regularly to keep it functioning as designed.

A clogged spark arrester :

- Prevents the flow of exhaust gas
- Reduces engine output
- Increases fuel consumption
- Makes starting difficult

If the engine has been running, the muffler and the spark arrester will be very hot. Allow the muffler to cool before cleaning the spark arrester.

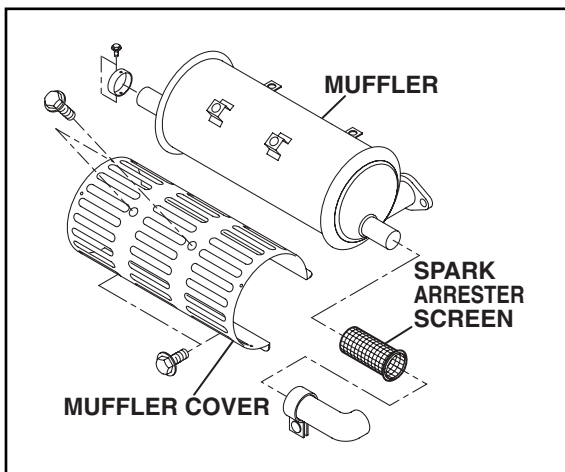

### How to remove the spark arrester

1. Remove the flange bolts from the muffler cover and remove the muffler cover.
2. Remove the special screw from the spark arrester and remove the spark arrester from the muffler.

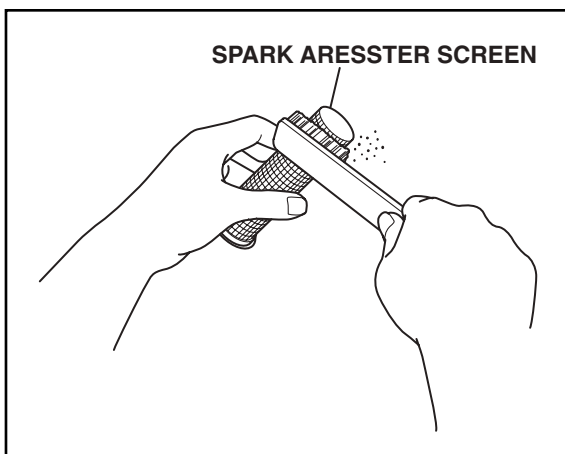

### Clean the spark arrester screen

Use a brush to remove carbon deposits from the spark arrester screen.

Be careful to avoid damaging the screen.

The spark arrester must be free of breaks and holes. Replace the spark arrester if it is damaged.

Install the spark arrester, and muffler protector in the reverse order of disassembly.

## **12-4 ENGINE STORAGE**

- (1) Change the engine oil and perform the daily maintenance items above mentioned.
- (2) Drain fuel from carburetor float chamber.
- (3) To prevent rust in the cylinder bore, apply oil through the spark plug hole and turn the crankshaft several turns by hand. Reinstall the plug.
- (4) Turn the crankshaft by hand and leave it where the resistance is the heaviest.
- (5) Clean outside of the engine with oiled cloth.
- (6) Put a plastic cover or the like over the engine and store the engine in dry place.



PRINTED IN THE USA